

EE 231 Lab 10

Build a Computer

A conceptual block diagram of a simple computer is shown in Figure 1. In previous labs you have already designed the Addr_Mux, the ALU, the control unit and the required registers. In this lab you will put all the components together to build a computer. The only missing block is the memory block which you can find here. You will also need the mem_init.v in which you are going to insert your program code. You are going to use graphical design to implement the computer as shown in Figure 1. Instructions on how to do that is provided in the prelab section 1.

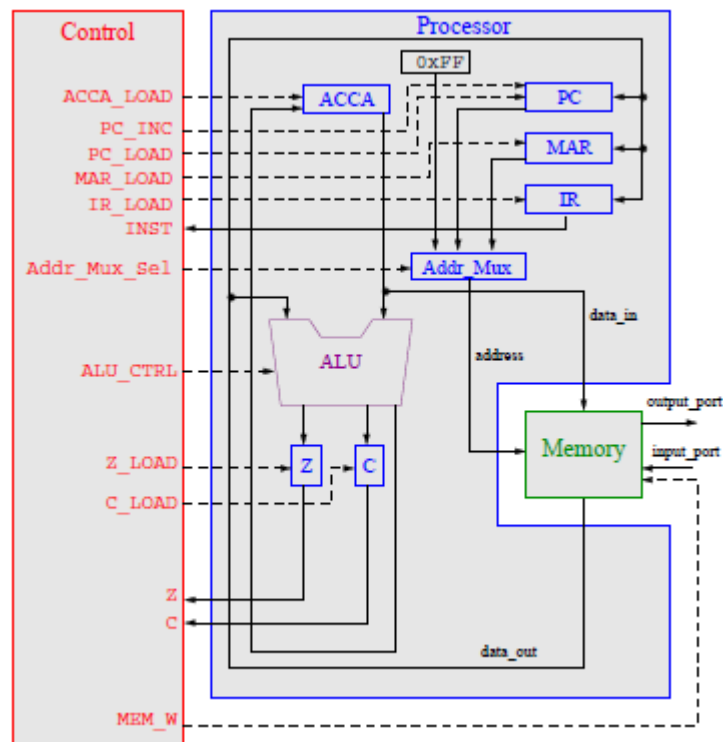

Figure 1. Simple Computer

1. Prelab

- Using the instruction set provided in the Appendix 3.1.1, write a computer program to generate running lights. One way to accomplish this is to start with an 8-bit number 0000 0001 (where the one represents the LED that would be off). Then left shift that number once you have reached the end, jump back to the beginning of the program. Figure 2 shows the expected output at different time steps.

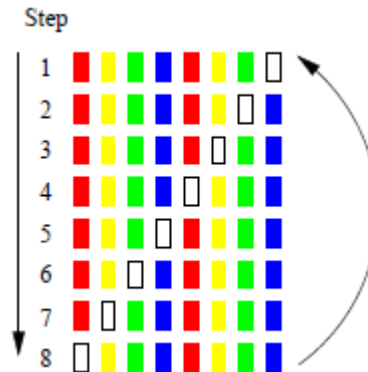

Figure 2: The sequence at which the LEDs turn on or off. The empty rectangles with black border represent and LED in the off state.

- Using the graphical method as shown in Section 3, design and build the entire computer.

1 Lab

- Enter your running light program into the mem_init.v file.
- Simulate the compute you have created in the prelab.
- Run your code on the Altera board.

3 Supplementary Material

3.1 Quartus

3.1.1 Graphical Design

- Start a new project and include the mem_block.v.
- Open the mem_block.v file and select File > Create/Update > Create Symbol Files for Current File. This creates a memory block as shown below.

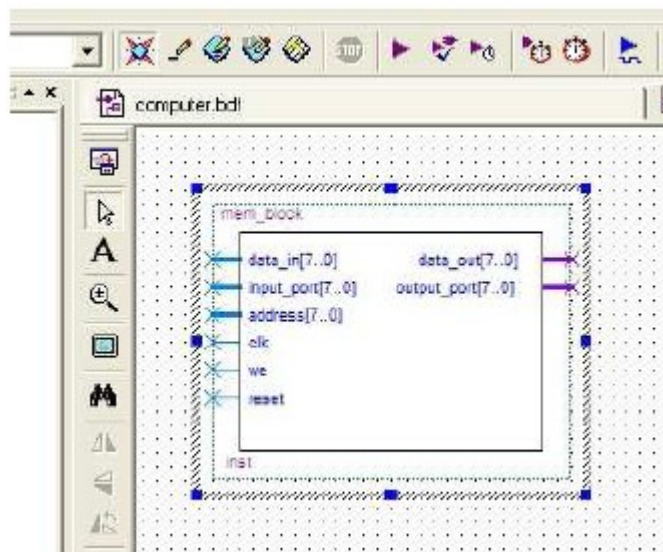

Figure 3. Memory Block Symbol

- 3 Open a block diagram file by File > New > Design Files > Block Diagram/Schematic file Input and output pins are located under primitives/pin. That creates a *.bdf file.
- 4 Right click in the main window and select Insert > Symbol.
- 5 Under you project directory select the mem_block you just created.
- 6 Keep adding the files that you have created in previous lab for remaining components of the computer. Each time create a Symbol file and added it to your main *.bdf file.
- 7 For the address mux and the reset constant you can use already existing block in Quartus. You can do that by Insert > Symbol, select ../quartus/libraries/, then select lpm_mux and/or lpm_constant which are located under megafunctions/gates. Input and output pins are located under primitives/pin.
- 8 Once you are done, start connecting the blocks as shown in Figure 1.

Appendix

Table 1: Computer Instructions

	Mnemonic	Operation
0	nop (no operation)	Do nothing
1	LDAA addr (load ACCA from mem- ory)	Loads ACCA with the value in memory at address addr. C stays the same, Z changes
2	LDAA_IMM #num (load ACCA with an im- mediate)	Loads ACCA with num, the value in memory at the address immediately following the LDAA #num command. C stays the same, Z changes
3	STAA addr (store ACCA in memory)	Stores the value in ACCA at memory address addr. C stays the same, Z changes
4	ADDA addr (add ACCA and value in memory)	Adds the value in memory location addr to the value in ACCA and saves the result in ACCA. C and Z change
5	SUBA addr (subtract value in mem- ory from ACCA)	Subtracts the value in memory location addr from the value in ACCA and saves the result in ACCA. C and Z change
6	ANDA addr (logical AND of ACCA and value in memory)	Perform a logical AND of the value in memory location addr with the value in ACCA. Save the result in ACCA. C stays the same, Z changes
7	ORAA addr (logical OR of ACCA and value in memory)	Perform a logical OR of the value in memory location addr with the value in ACCA. Save the result in ACCA. C stays the same, Z changes
8	CMPA addr (Compares ACCA to the value in addr)	Compare ACCA to value in addr. This is done by subtracting the value in addr from ACCA. ACCA does not change. C and Z change
9	COMA (Complement ACCA)	Replace the value in ACCA with its one's complement. C is set to 1 and Z changes
A	INCA (INCA ACCA)	Increment value in ACCA. C stays the same and Z changes
B	LSLA (logical shift left ACCA)	Logical shift left of ACCA. C and Z change
C	LSRA (logical shift right ACCA)	Logical shift right of ACCA. C and Z change

D	ASRA (Arithmetic shift right ACCA)	Arithmetic shift right of ACCA. C and Z change
E	JMP addr (jump)	Jumps to the instruction stored in address addr. The PC is replaced with addr. C and Z stay the same
F	JCS addr (jump if carry set)	Jumps to the instruction stored in address addr if C=1. If C is not set, continue with next instruction. C and Z stay the same
10	JCC addr (jump if carry not set)	Jumps to the instruction stored in address addr if C=0. If C is set, continue with next instruction. C and Z stay the same
11	JEQ addr (jump if Z set)	Jumps to the instruction stored in address addr if Z=1. If Z is not set, continue with next instruction. C and Z stay the same