

- **The MC9S12 address, data and control buses**
- **The MC9S12 single-chip mode memory map**
- Simplified write/read cycle
-
- **The real MC9S12 multiplexed external bus**
- Byte order in microprocessors
- How to determine if an MC9S12 bus cycle access one or two bytes
- A simplified input/output port
- A parallel output port which can be read
- A parallel input-output port

Address, Data and Control Buses

- A microprocessor system uses address, data and control buses to communicate with external memory and memory-mapped peripherals
- The address bus determines which memory location to access
- The control bus specifies whether **the memory cycle is a read** (into microprocessor) or **a write cycle** (out of microprocessor), and specifies timing information for the cycle
- The data bus contains the data being transferred during the memory cycle
- For example, consider the following simple MC9S12 program, which continuously increments the contents of address 0x0400:

```
org 0x2000  
loop:inc 0x0400  
bra loop
```

- The program is stored in memory starting at memory location 0x2000
- The MC9S12 Program Counter starts at address 0x2000
- The MC9S12 reads the first instruction, inc 0x0400, located in address 0x2000 through 0x2002
- The MC9S12 then reads the contents of memory location 0x0400, takes an internal memory cycle to increment the value, then writes the new value out to address 0x0400
- The MC9S12 then reads the next instruction, bra 0x2000
- The MC9S12 takes one memory cycle to load the program counter with the new value of 0x2000, and to clear its internal pipeline, then reads the instruction at 0x2000 to figure out what to do next

The MC9S12 address, data and control buses (simplified)

- Note: The following diagram assumes that the MC9S12 accesses one byte at a time
- The MC9S12 actually accesses two bytes (16 bits) at a time, when it can
- What actually occurs on the MC9S12 bus is a little more complicated than what is shown below

MC9S12 ADDRESS, DATA AND CONTROL BUS (SIMPLIFIED)

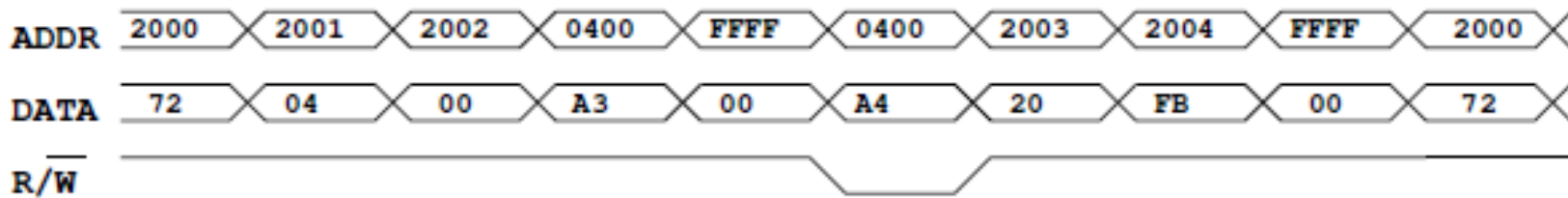

```

        .org 0x2000      2000: 72
loop:   inc 0x0400      2001: 04 } inc 0x0400
        bra loop       2002: 00
                          2003: 20 } bra 0x2000
                          2004: FB
    
```

The MC9S12 Memory Map

- The MC9S12 has address regions occupied by internal memory and peripherals
- A diagram showing which address regions are used is called a memory map
- Here is a memory map of the MC9S12DP256 with no added memory or peripherals

0x0000	Registers	1 KB
0x03FF	EEPROM	3 KB
0x0400		
0x0FFF	User RAM	11 KB
0x1000		
0x3EFF	D-Bug 12 RAM	1 KB
0x3C00		
0x3FFF	Flash EEPROM	16 KB
0x4000		
0x7FFF	Banked Flash EEPROM	16 KB
0x8000		
0xEFFF	D-Bug 12 Flash EEPROM	16 KB
0xC000		
0xFFFF		

The Expanded MC9S12 Memory Map

- We will add external peripherals to the MC9S12
- First, we will disable the Flash EEPROM at address 0x4000 through 0x7FFF (which we are not using anyway)
- Here is a memory map of the MC9S12DP256 with the peripherals we will add
- The peripherals will be put at 0x4000 and 0x4001

0x0000	Registers	1 KB
0x03FF		
0x0400	EEPROM	3 KB
0x0FFF		
0x1000	User RAM	11 KB
0x3BFF		
0x3C00	D-Bug 12 RAM	1 KB
0x3FFF		
0x4000	Unused Space	Use address 0x4000 - 0x4001 for external peripherals
0x7FFF		
0x8000	Banked Flash EEPROM	16 KB
0xBFFF		
0xC000	D-Bug 12 Flash EEPROM	16 KB
0xFFFF		

Simplified MC9S12 Write Cycle

- When the MC9S12 writes data to memory it does the following:
 - It puts the address it wants to write to on the address bus (when E-clock goes low)
 - It puts the data it wants to write onto the data bus
 - It brings the Read/Write (R/W) line low to indicate a write
 - The MC9S12 expects the external device at the given address will latch the data into its registers data on the falling edge of the E-clock

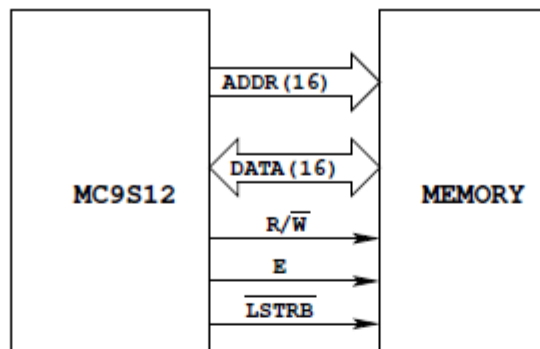

WRITE: MC9S12 puts address on address bus
 puts data on data bus
 brings R/W low
 Memory latches data on falling edge of E clock

Example: Write 0xfedc to address 0x3456 & 3457

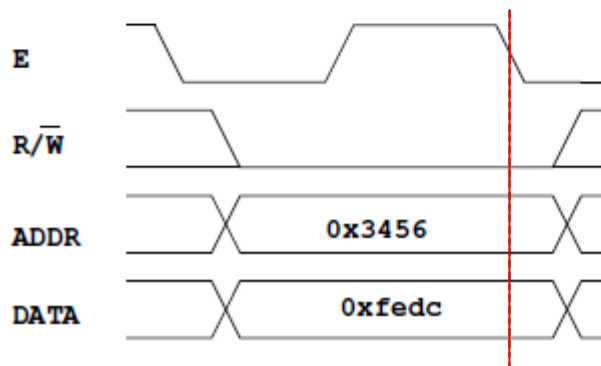

Simplified MC9S12 Read Cycle

- When the MC9S12 reads data from memory it does the following:
 - It puts the address it wants to read from on the address bus (when E-clock goes low)
 - It brings the Read/Write (R/W) line high to indicate a read
 - The MC9S12 expects the external device at the given address will put data on the data bus
 - On the falling edge of the E-clock, the MC9S12 latches the data into its internal register

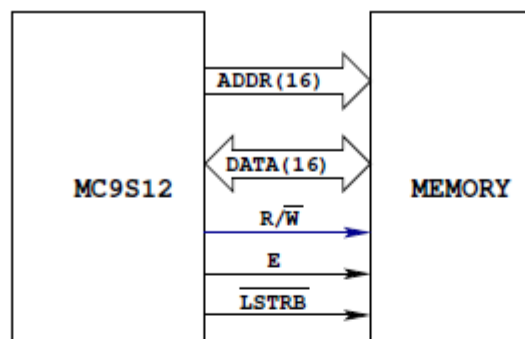

READ: MC9S12 puts address on address bus
brings R/W high
Memory puts data on data bus
MC9S12 latches data on falling edge of E clock

Example: Read from address 0x5678 & 0x5679

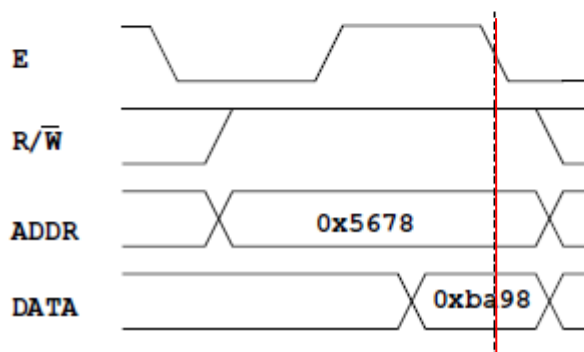

The Real MC9S12DP256 Bus

- Up to now we have been using the MC9S12 in Single Chip Mode
 - In Single Chip Mode the MC9S12 does not have an external address/data bus
- The MC9S12 can be run in Expanded Mode
 - In Expanded Mode the MC9S12 does have an external address/data bus
- Things are a little more complicated on the real MC9S12DP256 bus than shown in the simplified diagrams above
- The MC9S12DP256 has a multiplexed address/data bus
- The MC9S12DP256 sometimes accesses a single byte on a memory cycle, and it sometimes access two bytes on a memory cycle

The Multiplexed Address/Data Bus

- The MC9S12DP256 has a limited number of pins it can use
- To have full 16-bit address bus and a full 16-bit data bus the MC9S12DP256 would need to use 32 extra pins (in addition to several pins used for the control bus)
- To save pin count Motorola uses the same set of pins for several purposes
- When put into expanded mode, the MC9S12 uses the pins normally used for Ports A and B for its multiplexed address and data bus
 - When running in expanded mode you can no longer use Ports A and B as general purpose I/O lines
- The MC9S12 uses the same sixteen lines of Ports A and B for both address and data
- When the E-clock is low the sixteen lines AD15-0 are used for address
- When the E-clock is high the sixteen lines AD15-0 are used for data

The MC9S12 Address and Data Buses

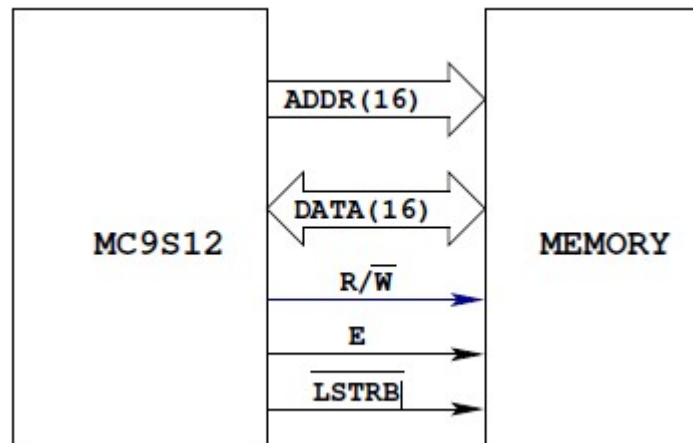

MC9S12 has 16-bit address and 16-bit data buses

Requires 35 bits

Not enough pins on MC9S12 to allocate 35 pins for buses and pins for all other functions

Memory Chip Interface

- Memory chips need separate address and data bus
 - Need way to de-multiplex address and data lines from MC9S12
- Memory chips need different control lines than the MC9S12 supplies
- These control lines are:
 - Chip Select – goes low when accessing memory chip
 - Write Enable – goes low when writing to memory
 - Output Enable – goes low when reading from memory
 - High Byte Enable – goes low when accessing the High Byte (Odd Address) of memory
 - Low Byte Enable – goes low when accessing the Low Byte (Even Address) of memory

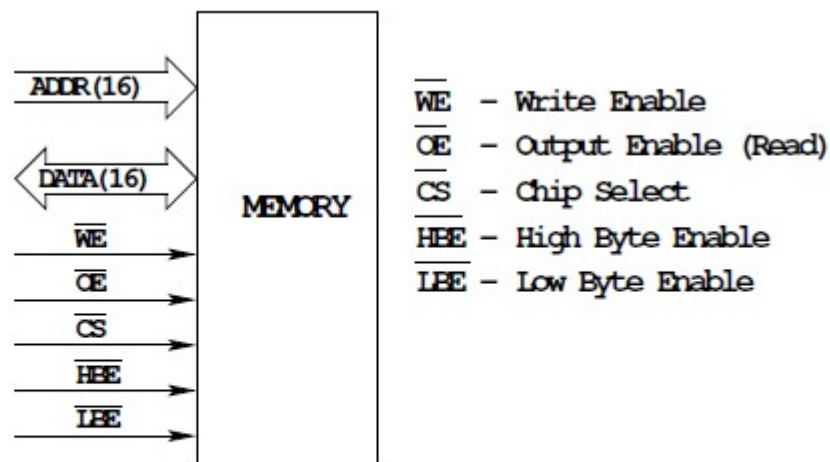

Memory needs separate address and data busses

Need way to separate address and data

The Multiplexed Address/Data Bus

- To talk to memory chip we will need to build a de-multiplexer between the MC9S12 and the memory chip

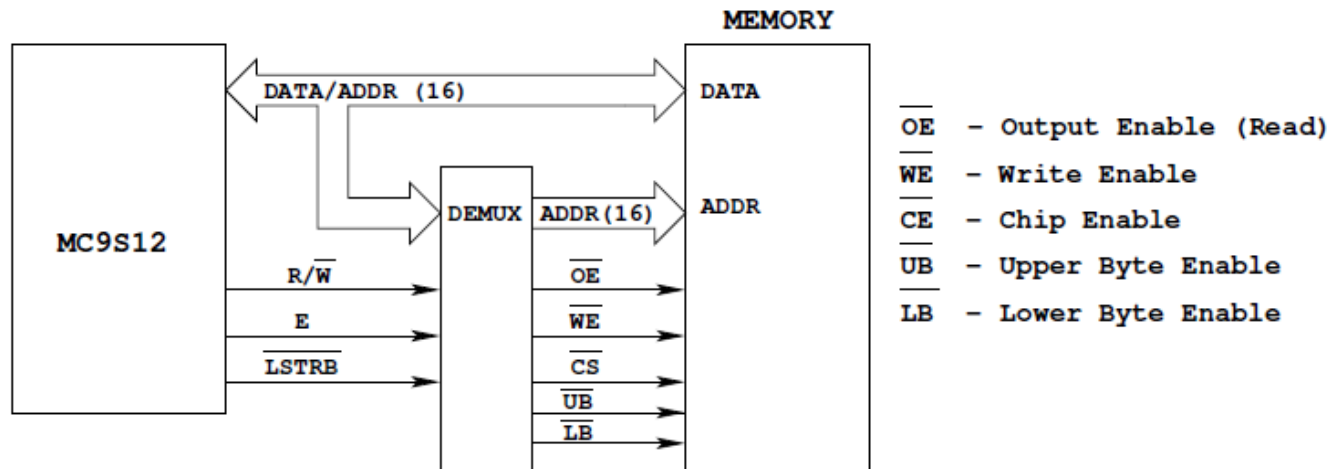

MCS12 has 16-bit address and 16-bit data buses
Requires 35 bits

Not enough pins on MC9S12 to allocate 35 pins
for buses and pins for all other functions

Solution: multiplex address and data buses
MC9S12 uses Ports A and B as multiplexed address/data bus
In expanded mode, you can no longer use Ports A and B for I/O

16-bit Bus: While E low, bus supplies address (from MC9S12)
While E high, bus supplies data (from MC9S12 on write, from memory on read)

Accessing External Memory and Ports on the MC9S12 in Expanded Mode

- In expanded mode, the MC9S12 has a multiplexed 16-bit address and data bus.
- With a 16-bit address bus, the MC9S12 can access $2^{16} = 65,536$ bytes of data
- With a 16-bit data bus, the MC9S12 can access 16 bits (two bytes) in a single bus cycle
- In expanded mode, the MC9S12 uses Port A and Port B as the multiplexed address/data bus
- Timing is controlled by the E clock

When the E clock is low, the MC9S12 places the address on the multiplexed bus

- Port A is used for address bits 15-8
- Port B is used for address bits 7-0

When the E clock is high, the MC9S12 uses the multiplexed bus for data

- Port A is used for the byte at the even address
- Port B is used for the byte at the odd address

Byte Order in Microprocessors

- There are two ways to store bytes in a microprocessor memory. For example, if you wanted to store the 16-bit word 0x1234 into memory locations 0x2000 and 0x2001, you could do it in two ways:

	Big Endian		Little Endian	
Address	0x2000	0x2001	0x2000	0x2001
Byte	0x12	0x34	0x34	0x12

- Motorola and Freescale (and some other manufacturers) use Big Endian (big end, or most significant part, appears first in memory, big part is in lower part of memory)
- Intel (and some other manufacturers) use Little Endian (little end appears first, smaller part of the number is in lower part of memory)
- Data types of more than one byte written on a Motorola machine will not be read properly on an Intel machine without first swapping byte order (and vice versa).
- In the discussion which follows, even byte refers to a byte at an even address, odd byte refers to a byte at an odd address. High byte refers to the most significant byte of a 16-bit word, low byte refers to the least significant byte of a 16-bit word.
- For the MC9S12, the high byte is at the even address, and the low byte is at the odd address for a 16-bit access.

How to determine if a bus cycle accesses one or two bytes

- Sometimes you only want to access one byte at a time. For example,
 - **ldaa \$4001** will access the single byte at address 0x4001.
- To determine whether it should access one byte or two bytes, the MC9S12 uses the $\overline{\text{LSTRB}}$ and A0 lines.
 - $\overline{\text{LSTRB}}$ low means that the MC9S12 is accessing the lower byte (byte at the odd address) of a sixteen-bit word
 - $\overline{\text{LSTRB}}$ high means that the MC9S12 is accessing the upper byte (byte at the even address) of a sixteen-bit word
 - A0 low means that the MC9S12 is accessing the upper (even) byte of a sixteen-bit word
 - A0 high means that the MC9S12 is accessing the lower (odd) byte of a sixteen-bit word

$\overline{\text{LSTRB}}$	A0	Type of Access
0	0	16-bit access of an even address Accesses bytes at even address and subsequent odd address
0	1	8-bit access of an odd address
1	0	8-bit access of an even address
1	1	Not allowed on external bus

- The instruction
 - **Idaa \$4000**

accesses the byte at address 0x4000, but doesn't access the byte at address 0x4001.

For this access, the MC9S12 will put 0x4000 on the bus ($A0 = 0$, access byte at even address), and will make $\overline{LSTRB} = 1$ (don't access byte at the odd address).

- The instruction
 - **Idaa \$4001**

accesses the byte at address 0x4001, but doesn't access the byte at address 0x4000.

For this access, the MC9S12 will put 0x4001 on the bus ($A0 = 1$, do not access byte at even address), and will make $LSTRB = 0$ (access byte at odd address).

- The instruction
 - **Idd \$4000**

accesses the bytes at addresses 0x4000 and 0x4001. For this access, the MC9S12 will put 0x4000 on the bus ($A0 = 0$, access byte at even address), and will make $LSTRB = 0$ (access byte at odd address).

- What to check for on the bus to determine if the MC9S12 is accessing a particular byte:
 - To check to see if the byte at address 0x4000 is being accessed, look for 0x4000 on the address bus (do not need to check LSTRB).
 - To check to see if the byte at address 0x4001 is being accessed, look for either 0x4000 or 0x4001 on the address bus (i.e., A0 is a don't care), and make sure LSTRB is low.

A Simple Parallel Input Port

- We want a port which will read 8 bits of data from the outside
- Such a port is similar to Port A or Port B when all pins are set up as input
- We need some hardware to drive the input data onto the data bus at the time the MC9S12 needs it to be there to read
- The hardware needs to keep the data off the bus at all other times so it doesn't interfere with data from other devices
- A **tri-state buffer** can be used for this purpose:
 - A tri-state buffer has three output states: logic high, logic low, and high impedance (high-Z)
 - In high-Z state it is like the buffer is not connected to the output at all, so another device can drive the output
 - A tri-state output acts like a switch - when the switch is closed, the output logic level is the same as the input logic level, and when the switch is open, the buffer does not change the logic level on the output pin
 - A tri-state buffer has a control input which, when active, drives the input logic levels onto the output pins, and when inactive, opens the switch

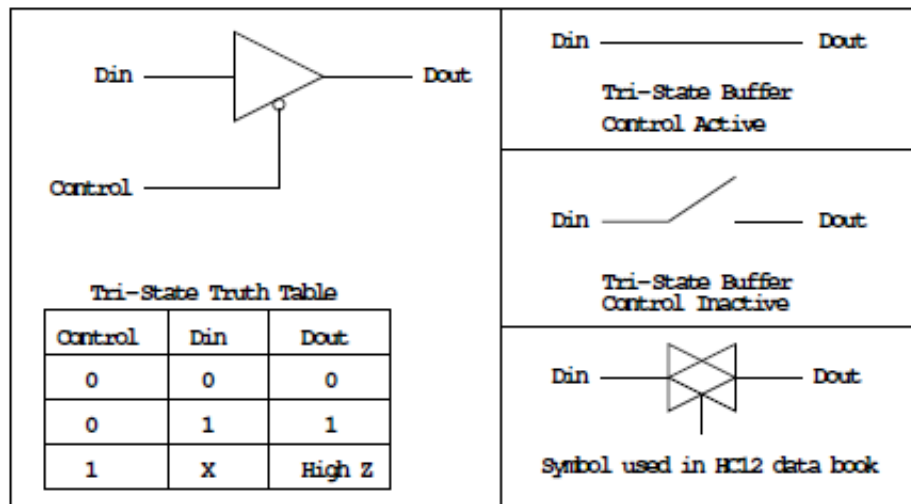

A Simple Parallel Input Port

- When should the tri-state buffer be enabled to drive the data bus?
 - The MC9S12 will access the buffer by reading from an address. We must assign an address for the tri-state buffer
 - We must have hardware to demultiplex the address from the data, and to determine when the MC9S12 is reading from this address
 - The 8-bit input will be connected to 8 bits of the 16-bit address/data bus of the MC9S12
- * If the address of the input is even, we need to connect the output of the buffer to the even (high) byte of the bus, which is connected to AD15-8 (what was Port A)

- * If the address of the input is odd, we need to connect the output of the buffer to the odd (low) byte of the bus, which is connected to AD7-0 (what was Port B)

- The MC9S12 needs the data on the bus on the high-to-low transition of the E-clock

- We must enable the tri-state buffer when:
 - 1. The address of the buffer is on the address bus**
 - 2. The MC9S12 is reading from this address**
 - 3. The MC9S12 is reading the high byte if the address is even, or the low byte if the address is odd**
 - 4. E clock is high**

- For example, consider an input port at address 0x4000 (an even address, or high byte):

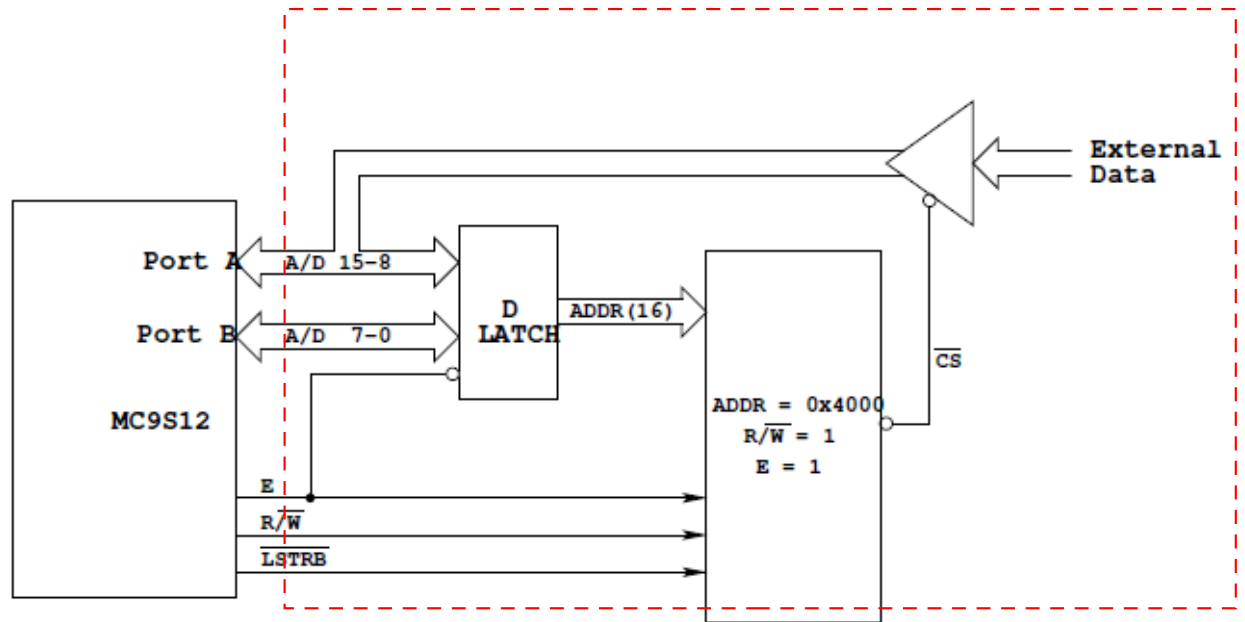

Example: Read from address 0x4000

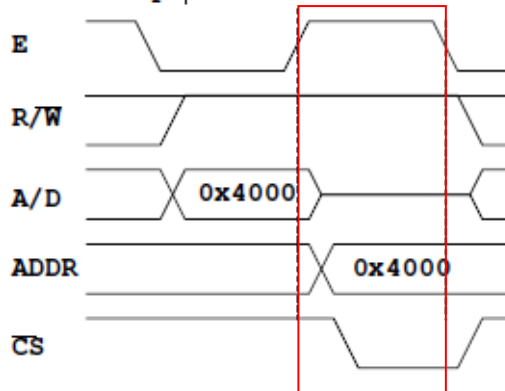

A Simple Parallel Output Port

- We want a port which will write 8 bits of data to the outside
 - Such a port is similar to Port A or Port B when all pins are set up as output
 - We need some hardware to latch the output data at the time the MC9S12 puts the data on the data bus
 - We can use a set of 8 D flip-flops to latch the data
 - The D-FF inputs will be connected to the data bus
 - The clock to latch the flip-flops should make its low-to-high transition when the MC9S12 has the appropriate data on the bus
 - The MC9S12 will access the flip-flops by writing to an address. We must assign an address for the flip-flops
 - We must have hardware to demultiplex the address from the data, and to determine when the MC9S12 is writing to this address
 - The 8-bit inputs of the D flip-ops will be connected to 8 bits of the 16-bit address/data bus of the MC9S12
- * If the address of the input is even, we need to connect the flip flop inputs to the even (high) byte of the bus, which is connected to AD15-8 (what was Port A)

- * If the address of the input is odd, we need to connect the flip flop inputs to the odd (low) byte of the bus, which is connected to AD7-0 (what was Port B)

- The hardware should latch the data on the high-to-low transition of the E-clock

- Our hardware should bring the clock of the flip-flops low when:
 - 1. The address of the flip-flops is on the address bus**
 - 2. The MC9S12 is writing to this address**
 - 3. The MC9S12 is writing the high byte if the address is even, or the low byte if the address is odd**
 - 4. E clock is high**

- For example, consider an output port at address 0x4001 (an odd address, or low byte):

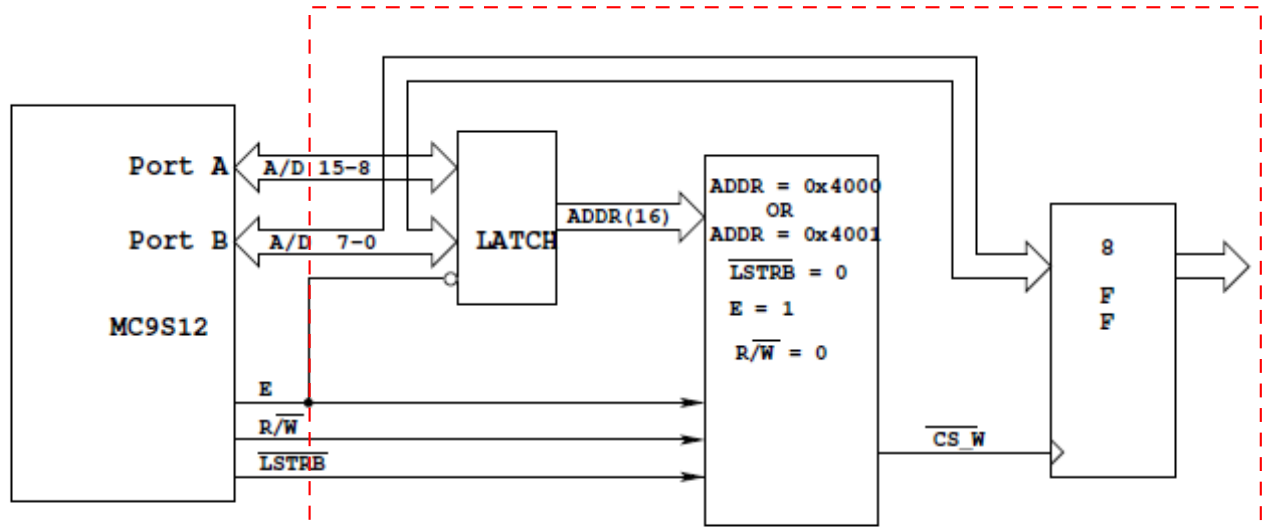

Example: Write an 0xAA to address 0x4001

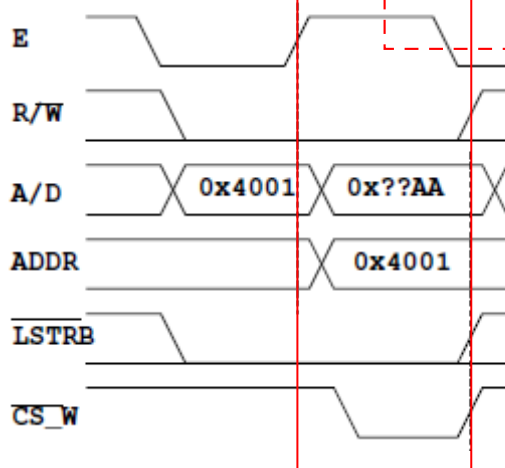

Note: ADDR can be 0x4000 or 0x4001 with LSTRB = 0

An Output Port Which Can Be Read

- Suppose we set up the MC9S12 Port A for output, and we write a number to Port A
- When we read from Port A, we will read back the number we wrote
- This is a useful diagnostic
- We can make our output port have this same behavior by connecting the output of the flip-flops back into the data bus through a tri-state buffer
- We should enable this tri-state buffer when the MC9S12 is reading from the address of the output port
- For example, consider the output port at address 0x4001:

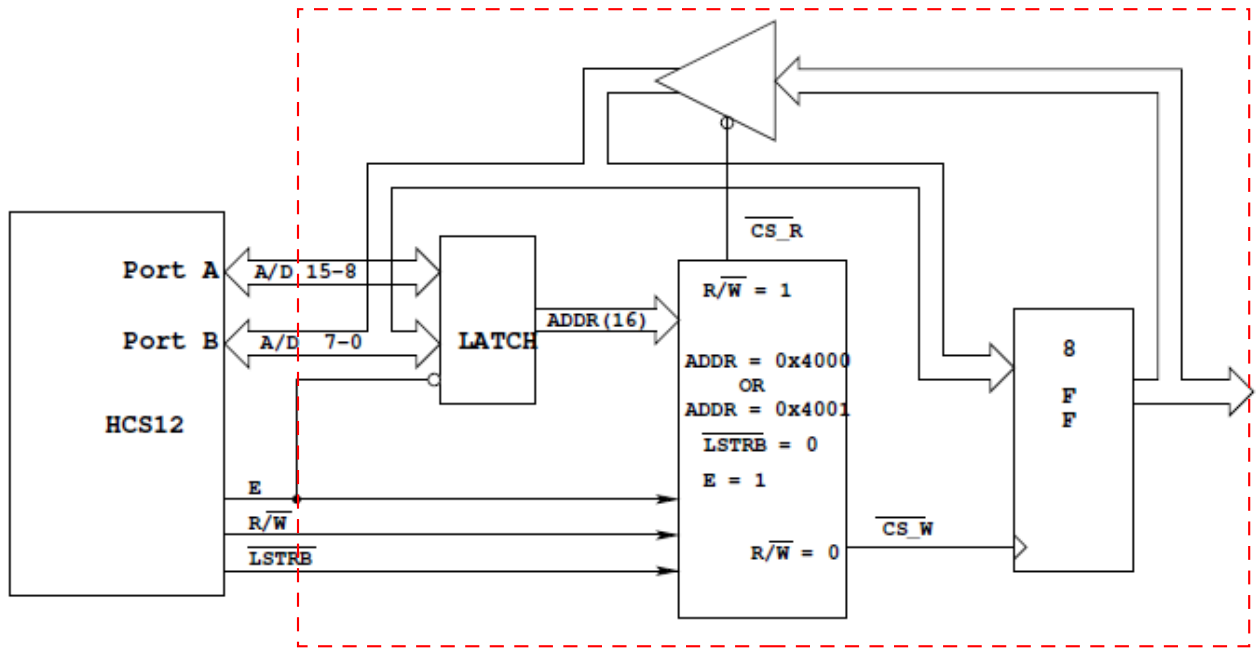

Writing to address 0x4001 will bring CS_W low.

On the high-to-low transition of E, CS_W will go high, latching the data into the flip-flops

Reading from address 0x4001 will bring CS_R low

This will drive the data from the flip-flops onto the data bus

The HC12 will read the data on the flip-flops on the high-to-low transition of the E-clock

An Input-Output Port

- Like Port A, we can make a port be either input or output
- To do this we need a **data direction bit** (at another address), and a tri-state buffer on the outputs of the flip-ops
- For simplicity, we will make all bits inputs or all bits outputs rather than allowing any individual bit to be either an input or an output
- The data direction bit is simply a flip-flop which is set or cleared by the MC9S12
- When the data direction bit is cleared, the data from the output flip-flops will be removed from the external pins
 - When we read from the port, we will read the logic levels on the pins put there by external logic
- When the data direction bit is set, the data from the output flip-flops will be put on the external pins
 - When we write to the port, we will drive the data from the flip-flops onto the external pins

- For example consider an I/O port at address 0x4001. The direction of the port is determined by a data direction bit at address 0x4002:

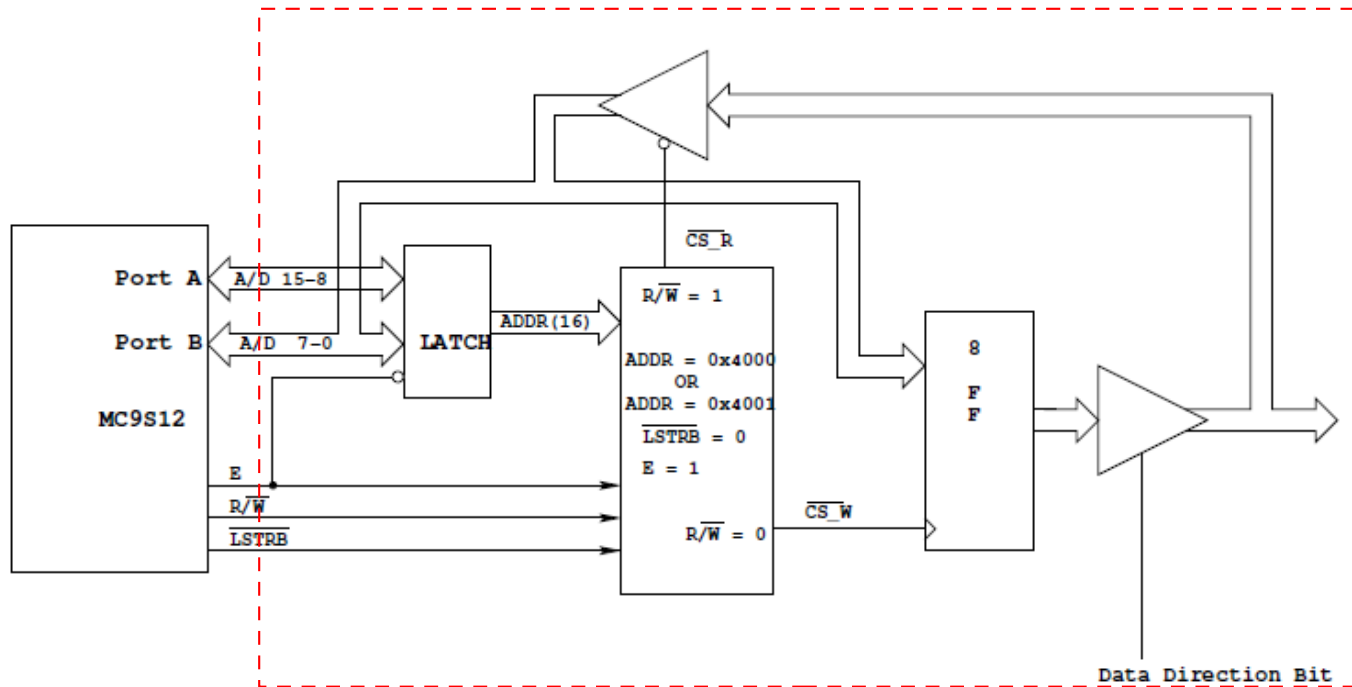

The data direction bit is the output of a flip-flop which was written to at another address of the MC9S12. For example, it could be Bit 4 of address 0x4002.

Writing a 0 to Bit 4 of address 0x4002 disables the output tri-state buffer.

When we write to address 0x4001 we will latch the data into the flip-flops.

This data will not be driven onto the external pins.

When we read from address 0x4001, we will read what an external device drives onto the pins.

Writing a 1 to Bit 4 of address 0x4002 enables the output tri-state buffer.

When we write to address 0x4001 we will latch the data into the flip-flops.

This data will be driven onto the external pins.

When we read from address 0x4001 we will read the data latched into the flip-flops.