

Lab 3 Instrumentation Amplifier

Pre-Lab

1. Design the difference amplifier in step 1.
2. Design the first stage in step 5.
3. Sketch the complete instrumentation amplifier including the nulling circuit in step 9, with all resistor values.
4. Research the Wheatstone bridge and understand how it works.

In this lab we will build a difference amplifier, then add a input stage which turns it into a instrumentation amplifier. Then we will use the instrumentation amplifier to look at the small signal produced by a strain gauge. The instrumentation amplifier will have an overall gain of approximately 600, evenly divided between the first and second stages.

Difference amplifier

In this section you will build the difference amplifier, the second stage of the instrumentation amplifier, and characterize its response.

1. Construct a difference amplifier (using a LF 411) with a gain of about 25, using resistors of at least $5\text{ k}\Omega$ on the inputs. When picking resistors measure a few and pick them such that there is minimal difference between those which should be equal.
2. Attaching a 1 kHz signal to both inputs, verify that the common-mode gain is small. What is the common-mode gain, A_C ? If you built your amplifier carefully you should get $|A_C| \ll 1$.
3. Attach a small-amplitude signal to one input and ground the other. This input signal has both common-mode and differential mode. The common-mode, v_{Ic} , is the average of the two inputs, and the differential mode, v_{Id} , is the difference between the two inputs. The output is then $v_O = v_{Id}A_D + v_{Ic}A_C$, where you can measure v_O and know everything else. Calculate A_D .
4. From your previous measurements compute the common-mode rejection ratio (CMRR), $|A_D/A_C|$, including in dB ($20 \log_{10}$). The larger the CMRR, the better.

Instrumentation amplifier

In this section you will build the first stage of the instrumentation amplifier, verify that it works, attach it to the second stage, and tune the instrumentation amplifier to maximize the CMRR.

5. Construct the first stage of the instrumentation amplifier (using two LF 411s) to have a gain of 25 using resistors of at least 5 k Ω .
6. Verify that the common-mode gain is approximately unity: attach a signal to both inputs and verify that the two outputs are nearly equal and equal to the input.
7. Verify that the differential-mode gain is approximately 25: attach a signal to one input, ground the other, and verify that the difference between the two outputs is approximately 25 times the difference between the two inputs.

(Note that this is a two-input, two-output amplifier, such that the output has both a common-mode and a differential mode. We can generalize the concept of common-mode and differential mode gains

$$v_{Oc} = A_{DC}v_{Id} + A_{CC}v_{Ic}$$

$$v_{Od} = A_{DD}v_{Id} + A_{CD}v_{Ic}$$

However, in this lab, to simplify, we assumed, in the two previous steps, that a common-mode input results in a common-mode output and that a differential mode input results in a differential mode output.)

8. Connect the two outputs to the input on the difference amplifier to create the full instrumentation amplifier.
9. Measure the common-mode and differential mode gains as you did for the difference amplifier in step 2 and compute the common-mode rejection ratio.
10. Tune the amplifier: it is possible to increase the CMRR by adjusting the various components. We will look at only one adjustment: attach the input nulling offset circuit to one of the input amplifiers, attach a common-mode inputs signal as in step 2, and adjust the nulling circuit to minimize the response on the output to the common-mode input. Assuming A_D is unchanged, what is the new CMRR?

Strain Gauge

In this section you will use the instrumentation amplifier to measure the small deflection of a bar as you bend it. A strain gauge is attached to the bar and as the bar is bent the resistance of the strain gauge changes slightly, less than 1%. You will use a Wheatstone bridge (which consists of two voltage dividers in parallel) to convert the small resistance change into a small voltage which is then amplified by the instrumentation amplifier.

11. Measure the resistance of the strain gauge. It should be close to 120 Ω .

12. Construct a Wheatstone bridge as depicted, and adjust the potentiometer such that if you apply a AC signal on the inputs (top and bottom), you get zero output with the strain gauge bar at rest. The resistor network on the same arm as the strain gauge can be adjusted by a small amount around the strain gauge resistance.

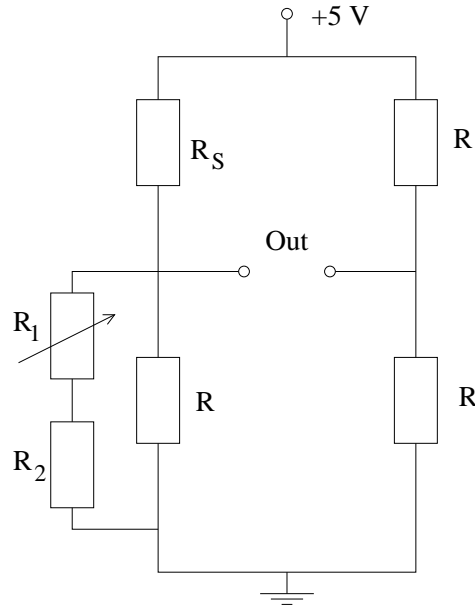

R_S is the strain gauge. R should be slightly larger than R_S (perhaps $121\ \Omega$ if $R_S = 120\ \Omega$), and R_1 and R_2 should be much larger, $10\ \text{k}\Omega$ (for $\pm 0.5\%$ adjustment range) or $1\ \text{k}\Omega$ (for $\pm 5\%$ adjustment range). You may need to experiment by varying the values of the resistors R slightly to give you the adjustment range you need.

13. Attach the output of the Wheatstone bridge to the input of the instrumentation amplifier and watch the output signal change as you flex the bar.
14. Extra credit: can you find a way to capture a waveform from the bar oscillating by triggering on an electrical signal generated as you hit the bar (gently!)? It may be as simple as one person triggering immediately prior to the other hitting the bar.