

Lab 6 Voltage regulators, Clamping, voltage doubler

Pre-Lab

1. Compute the value of R in step 1.
2. Compute the resistance at which regulation stop, in step 4.
3. Estimate the regulation in step 5 from r_z obtained from the data sheet.
4. In step 7 pick the value of the other resistor.
5. Draw the circuit in step 12.
6. Describe what you expect to see in step 14 and 16.
7. Draw the circuit in step 17.

In this lab we will look at voltage regulation using Zener diodes, then at limiting and clamping circuits, and finally at the voltage doubler circuit.

Simple Zener regulator

In this section you will build a simple Zener regulator and characterize it.

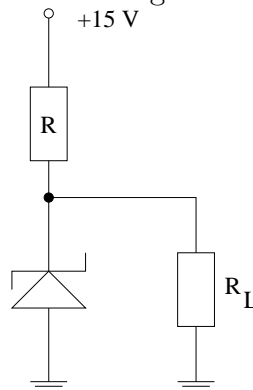

1. Build the simple 8.2V Zener regulator using a 1N5237 and a 15V source. Adjust the value of R to make the current through the Zener diode approximately 20 mA.
2. Without a load, measure the output voltage (with a multimeter for accuracy) and compute the actual current.
3. Attach a 1 k Ω load resistor, measure the output voltage again and compute the current through the diode. What is the Zener resistance, $r_z = \frac{\Delta v_z}{\Delta i_z}$?

4. At what load resistance, roughly, do you expect the Zener diode current to drop to zero? What happens as you continue decreasing the load resistance from that point? Verify this somehow and describe it in your lab book.
5. With the $1\text{ k}\Omega$ load resistor in place, vary the input voltage (for example between 13 V and 17 V). What is the regulation, $\frac{\Delta v_{\text{out}}}{\Delta v_{\text{in}}}$. Compare this regulation to a theoretical prediction based on r_z .

A better Zener regulator

In this section you will build a better Zener regulator.

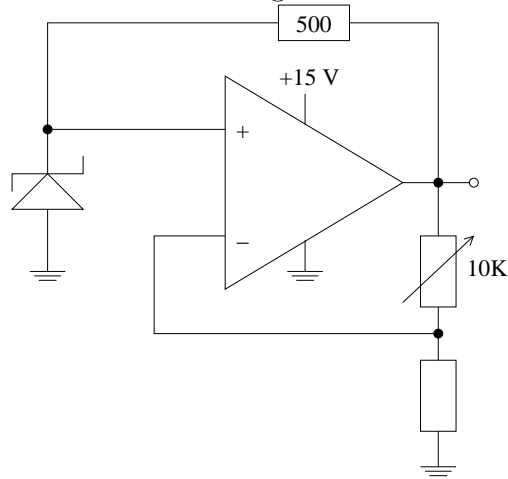

6. Build this Zener regulator circuit. Note that in this case the current through the Zener diode is independent of the current being drawn at the output. The circuit has two stable states, and to avoid it picking the negative output voltage stable state we attach the negative supply to ground.
7. Use a $10\text{ k}\Omega$ potentiometer in the feedback path (what should be the value of the other resistor?), and pick a 10 V output.
8. Can you measure the regulation now? What is the lower limit of the regulation?

Limiter circuits

In this section you will characterize two different limiter circuits.

9. Build this circuit.

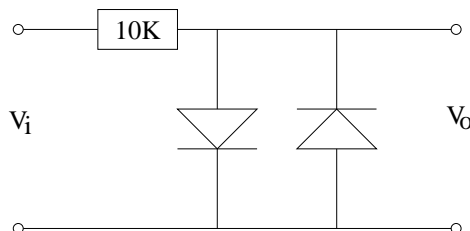

10. Apply an input 1 V amplitude sine wave, plot the input and the output. Explain the result.
11. In XY mode plot the transfer function between input and output. Explain the result.
12. Now replace the two parallel diodes with two 4.3 V Zener diodes in series, with opposite polarity and repeat the two previous steps for a sufficiently large amplitude sine wave (how large?) to produce interesting results. Explain the result.

Clamping circuit

In this section you will look at the clamped capacitor circuit.

13. Build this clamped capacitor circuit.

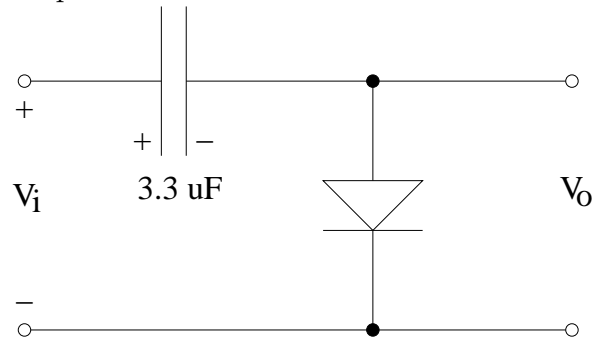

14. Apply a sine wave of 2 V amplitude. Plot the input and output.
15. Explain the relationship between the input and the output.
16. Add a positive offset to the input. Plot and explain the result.

Voltage doubler circuit

17. Expand the clamped capacitor circuit to construct the voltage doubler described in the text book. Use a second $3.3 \mu\text{F}$ capacitor. What should be its polarity?
18. Plot the input and output together and explain the result.