

Lab 8 Voltage-Controlled Voltage Source Active Filters

In this lab you will build and characterize Butterworth and Chebyshev filters according to the recipes in Horowitz and Hill section 5.06-5.07.

Pre-lab

1. Compute the theoretical amplitude, phase, and step responses for the 2nd order Butterworth filter for $f_0 = 10$ kHz.
2. Compute the theoretical amplitude, phase, and step responses for the 4th order Butterworth filter for $f_0 = 10$ kHz.
3. Compute the theoretical amplitude, phase, and step responses for the 2nd order 2dB Chebyshev filter for $f_0 = 10$ kHz.
4. Pick R , C , R_1 , and R_2 for every 2nd order filter term used in this lab.

Extra credit:

5. Compute the theoretical amplitude, phase, and step responses for the 4th order 2dB Chebyshev filter for $f_0 = 10$ kHz.

Butterworth Filter

Build a 2nd order and a 4th order Butterworth filter with a critical frequency of $f_0 = 10$ kHz.

1. In this lab we will always work with this same basic second order circuit, pictured here. It is a variation of the Sallen-and-Key low-pass filter.

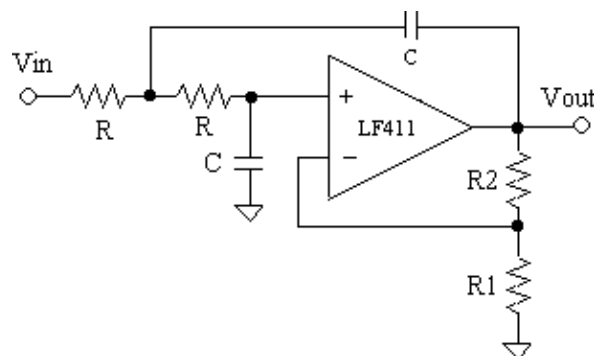

2. Build a second order Butterworth filter with 3-dB cutoff frequency of $f_0 = 10$ kHz. Remember that if you attach the function generator directly to the input that either you should make R much larger than the output resistance of the function generator (50Ω), or you should include it in your calculation.

3. Measure the amplitude and phase response as a function of frequency from 1 kHz to 20 kHz and compare with theory. The theoretical comparison should consist of a matlab plot of the same filter.
4. Measure the step response and compare with theory.
5. Build a 4th order Butterworth filter with the same parameters and measure its amplitude and step responses only. Compare with theory.

Chebyshev Filter

Build a 2nd order 2 dB Chebyshev filters and measure its response.

6. Build the 2nd order 2 dB Chebyshev filter with the same cutoff frequency.
7. Measure the amplitude and phase response and compare with theory. In particular make sure you measure the ripple.
8. Measure the step response and compare with theory.

Extra credit:

9. Build the 4th order 2 dB Chebyshev filter with the same cutoff frequency.
10. Measure the amplitude and step responses and compare with theory.