

EE 322 Advanced Electronics, Spring 2012

Exam 1

Monday February 27, 2012

Rules: This is a closed-book exam. You may use only your brain, a calculator and pen/paper. Each numbered question counts equally toward your grade.

Note: The questions are designed to test your conceptual understanding, not your ability to do many pages of math. If you find yourself doing long calculations there is a high probability that you are doing something wrong.

Linear regulator

1. The LM7805 linear regulator is 3-pin 5 V regulator accepting input voltages greater than 7 V. Sketch how to connect the LM 7805 and a bypass power BJT to provide greater current than that LM 7805 is capable of.

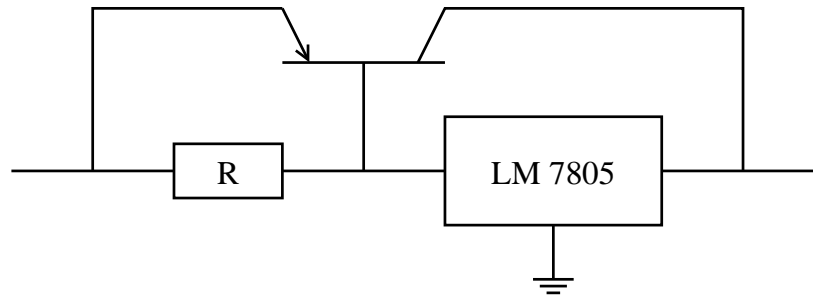

2. Now assuming a 15 V input source and a power dissipation limit of 1 W for the LM 7805, select components for your design such that the power dissipation limit is not exceeded.

The voltage drop is $\Delta V = 10\text{ V}$. The power is $P = \Delta V I$, so the maximum current is

$$I_{\max} = \frac{P}{\Delta V} = \frac{1}{10} = 100\text{ mA}$$

The BJT turns on when the voltage drop across the resistor R equals $V_R = 0.5\text{ V}$, so

$$R = \frac{V_R}{I_{\max}} = \frac{0.5}{0.1} = 5\ \Omega$$

Switched capacitor supply

3. Design a inverting switched capacitor supply. I.e. one which takes as input 5 V and provides as output -10 V. You may use any or all of the following: the 5 V supply, a 0-5 V clock signal generated by the 5 V supply, one or more digital inverters (5 V input gives 0 V output and vice versa), capacitors, and ideal diodes.

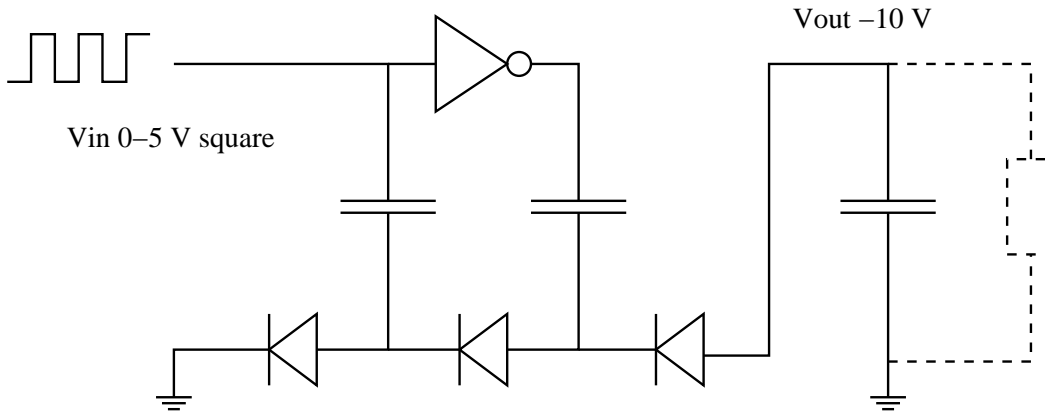

Inductor switched regulator

4. Draw a inverting switching regulator of the kind we studied in Horowitz and Hill.

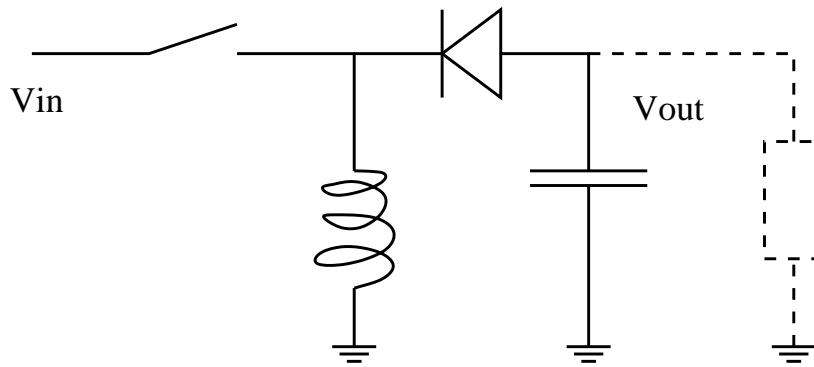

5. Carefully plot the inductor current and voltage as a function of time for the case of 5 V input and -15 V output, for both continuous and discontinuous mode operation.

First we need to find out the relationship between T_C and T_O . We have

$$T_C \left(\frac{dI}{dt} \right)_C + T_O \left(\frac{dI}{dt} \right)_O = 0$$

$$T_C V_{in} - T_O V_{out} =$$

$$\frac{T_C}{T_O} = -\frac{V_{out}}{V_{in}}$$

inserting values we get

$$\frac{T_C}{T_O} = -\frac{-15}{5} = 3$$

in continuous mode. This is also the ratio between the time of increasing and decreasing current in discontinuous mode. First for continuous mode

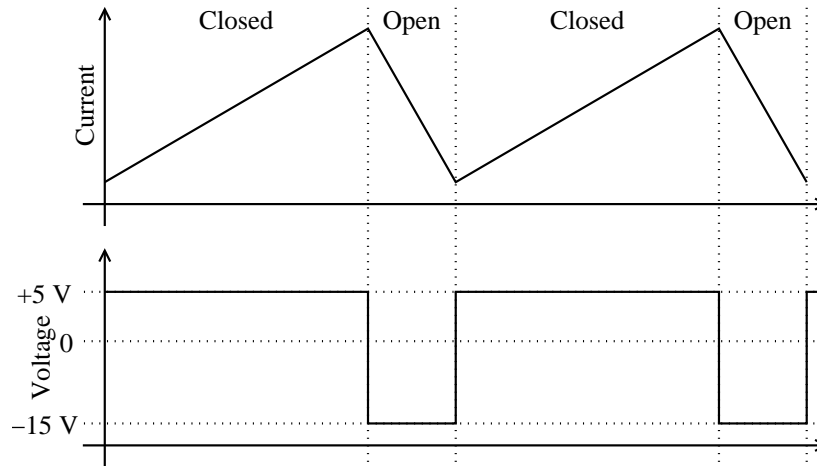

and next for discontinuous mode

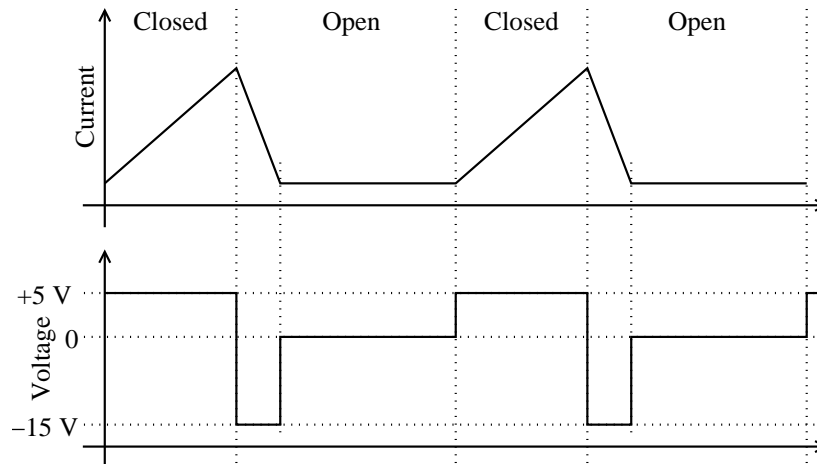

6. If you have only a $100\ \mu\text{H}$ inductor, what switching frequency should you choose to limit the current variation to $100\ \text{mA}$?

We have

$$V = L \frac{dI}{dt} = L \frac{\Delta I}{T_C}$$

$$T_C = \frac{L}{V} \Delta I = \frac{100 \times 10^{-6}}{5} \times 100 \times 10^{-3} = 2\ \mu\text{s}$$

$$f = \frac{1}{T_C + T_O} = \frac{1}{T_C + \frac{1}{3}T_C} = \frac{3}{4} \frac{1}{T_C} = \frac{3}{4} \frac{1}{2 \times 10^{-6}} = 375\ \text{kHz}$$

7. If the load current is $1\ \text{A}$, what is the average current through the $100\ \mu\text{H}$ inductor?

We need to be careful with this question because it is not simply taking the ratio of voltages and assuming that is the inverse of the ratio of currents. Instead we have to look at the amount of charge transferred. The amount of charge removed in $T_C + T_O$ by the load current must be replenished during T_O by the inductor. Thus we have the relationship that

$$I_{\text{load}}(T_C + T_O) = \langle I_L \rangle T_O$$

(remember the average of the inductor current is the same during the charging and discharging phase because it varies linearly between the same two extrema). We then have

$$\langle I_L \rangle = I_{\text{load}} \frac{T_C + T_O}{T_O} = 4I_{\text{load}} = 4 \text{ A}$$