

EE521 Fall 2006  
Final Exam  
Dr. Anders M. Jorgensen

Due 9:00AM on Monday December 11. You may bring a paper copy of your answers to my office, Workman 245, or you may e-mail your answers to me as a formatted document. Each problem is worth 10 points.

Please use symbolic math as much as possible. Define symbols if you need them. Please include correct units on all reported quantities. Please show details of derivations.

**Problem 1: Noise in circuits**

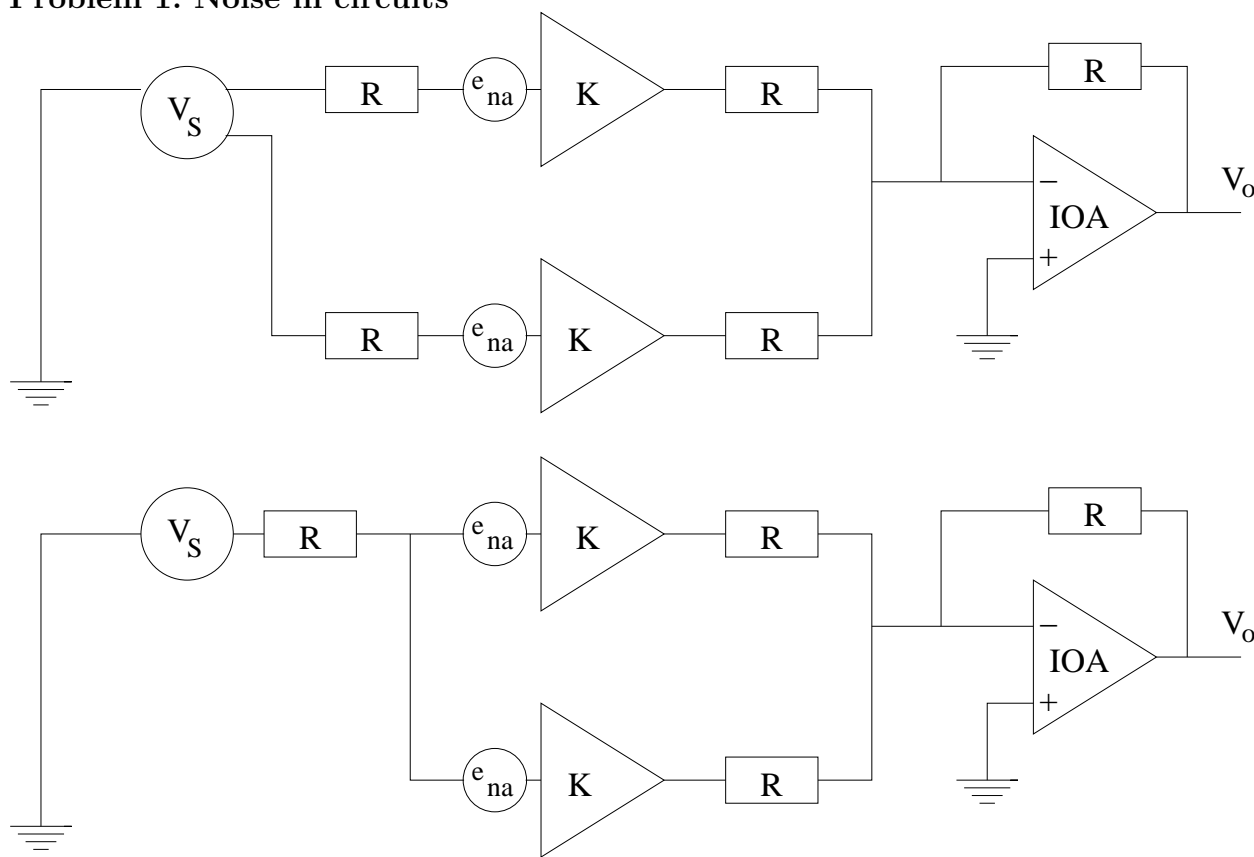

- (A) Derive an expression for the output SNR of the first circuit shown above.
- (B) Derive an expression for the output SNR of the second circuit shown above.
- (C) Which of the two circuits produces better SNR?
- (D) Notice that input noise is ignored for the IOA. Explain why this is often permissible.

**Problem 2: Filters**

Each of the following questions have short answers.

- (A) Write a transfer function for a simple first order low-pass filter.
- (B) Write a transfer function for a simple first order high-pass filter.
- (C) Explain what a bi-quad filter is.
- (D) What is the difference between a Butterworth filter and a Chebychev filter?
- (E) What is one advantage of a Elliptic filter over Butterworth and Chebychev filters?  
What is a disadvantage?

**Problem 3: Wheatstone bridge**

An ideal differential amplifier with gain  $K = 10^3$  is used to amplify the voltage output of a equal resistance Wheatstone bridge in which one of the resistors has a small additive variable resistance. Following the differential amplifier is a filter with unity gain in a pass-band of width 1 Hz centered on 100 Hz. The resistor values are  $100\ \Omega$  each at 270 K, the bridge is excited with a 100 Hz sinusoidal voltage with an amplitude of 1 V, and the differential amplifier has white input noise with  $e_{na} = 10\ \text{nV}/\sqrt{\text{Hz}}$ .

- (A) Draw the circuit.
- (B) Derive an algebraic expression for the minimum resolvable resistance change.
- (C) Insert the given numbers to compute the actual minimum resolvable resistance change.
- (D) What is the dominant source of noise?

#### Problem 4: Amplifier

- (A) A differential amplifier is given DC inputs of  $V_i = 1.234$  mV, and  $V_i' = 0.136$  mV, and produces an output of  $V_o = 1.911$  V. It is then given DC inputs of  $V_i = 0.556$  mV and  $V_i' = 1.234$  mV and produces an output of  $V_o = -0.8217$  V. Compute the differential mode gain, the common mode gain, and the common mode rejection ratio.
- (B) Assume that the amplifier's transfer function is described by a first order low-pass transfer function. Plot the bode diagram of the transfer function.
- (C) The amplifier is now given a purely differential sinusoidal input where  $V - V'$  has amplitude 1 mV, and frequency 1 kHz. The output is a sinusoid with amplitude 25.0 mV. Compute the filter time-constant and the value of the Gain-Bandwidth product.

**Problem 5: Resistive sensor**

A potentiometer excited by a DC voltage is used to measure angular position. The potentiometer has a full range of two turns.  $1/f$  noise cannot be ignored. The center pin voltage is conditioned by a differential amplifier with unit gain, and input noise power spectrum  $e_{na}^2$ . That is followed by a RC filter.

- (A) Draw the circuit.
- (B) Derive the DC relationship between angle and output voltage.
- (C) Derive an expression for the noise power spectrum at the output. Assume that all of the potentiometer resistance contributes Johnson noise, and do not ignore  $1/f$  noise.
- (D) Derive an expression for the RMS noise output voltage. You may drop the  $1/f$  noise at this point.
- (E) Derive an expression for the resolution of the angle measurement. Plug in typical values, for example 10 V for the potentiometer excitation voltage,  $10^4\Omega$  for the potentiometer resistance,  $20\text{ nV}/\sqrt{\text{Hz}}$  for the amplifier, and  $10^3\Omega$  for the resistor in the RC circuit, and a time-constant for the RC filter of 0.01 s.
- (F) Based on your answer to question (E), discuss whether all resolution-limiting factors have been taken into account. If not, what are other sources of uncertainty, and how would you incorporate those into and overall estimate of the positioning accuracy?

Problem 6: Digital to Analog Converter

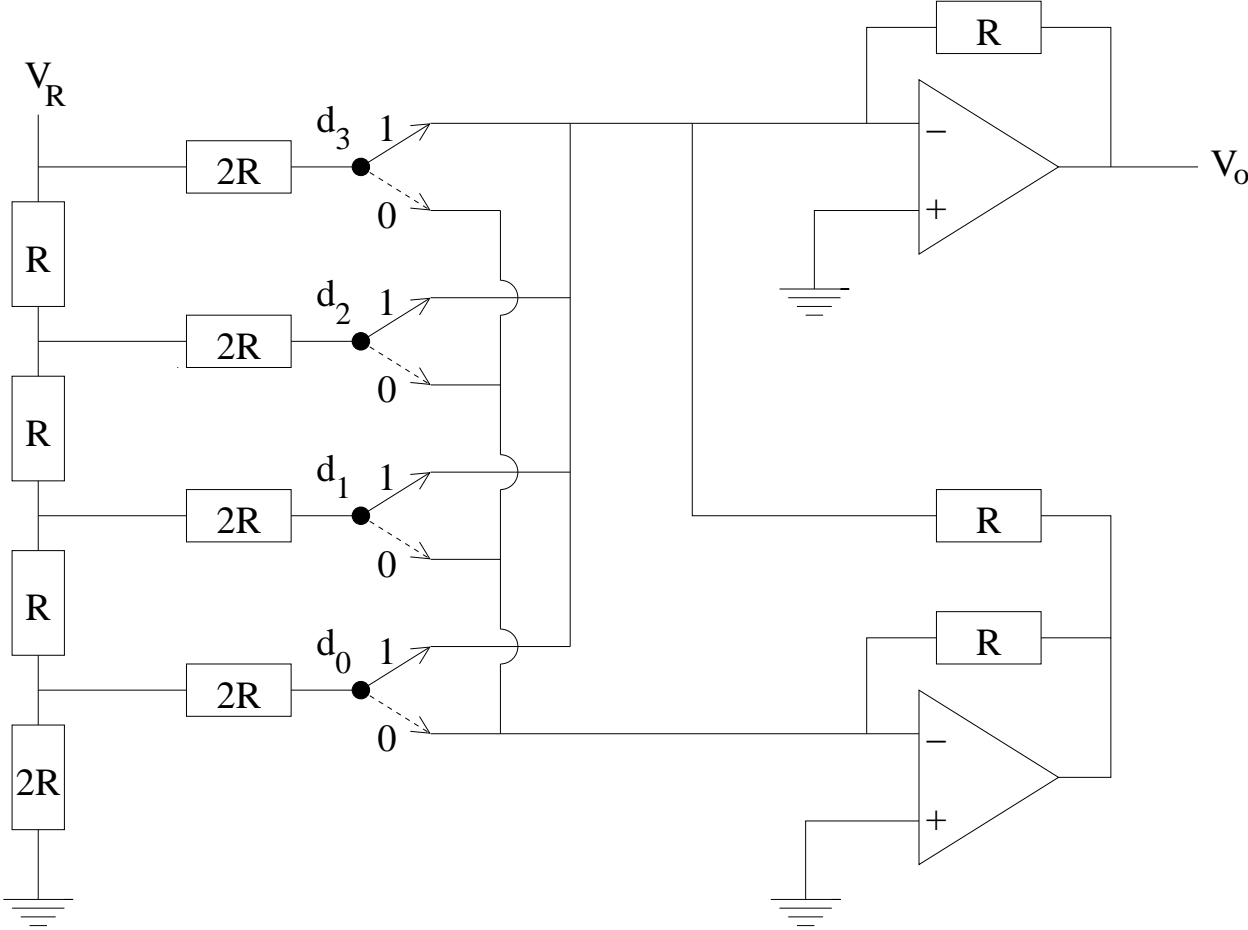

The figure shows a 4-bit R-2R digital-to-analog converter.

- (A) Derive the transfer function from  $\{d_0, d_1, d_2, d_3\}$  to  $V_o$ . In other words, derive an expression for  $V_o$  in terms of  $\{d_0, d_1, d_2, d_3\}$ .
- (B) Give the exact range of possible output voltages.