



<http://www.cubesatkit.com/>

CubeSat Kit™

Linear EPS

Hardware Revision: D

Rechargeable Electrical Power System for CubeSat Kit Bus

Applications

- CubeSat Kit demonstrations
- CubeSat Kit terrestrial testing
- CubeSat Kit balloon missions

Features

- Unregulated battery power for CubeSat Kit Bus
- Regulated +5V and +3.3V power for CubeSat Kit Bus
- Long runtimes via two user-replaceable 3.7V 1500mAh iPod® Li-Poly rechargeable batteries¹
- For use with all 104-pin CubeSat Kit Bus modules²
- No switching noise – uses automotive-grade LDO linear voltage regulators
- Very low quiescent current drain
- Stackable for current doubling, etc.
- Provides EPS telemetry via I2C interface³
- Recharges in-situ via CubeSat Kit's USB connector
- LED bargraph indicates charging progress and battery status
- Auto-resetting overcurrent trip fuses on battery, +5V and +3.3V outputs
- On-board reset supervisor for maximum reliability
- FM430 Remove-Before-Flight switch provides complete power disconnect via battery ground lift through CubeSat Kit Bus
- FM430 Deployment switch provides power disconnect through CubeSat Kit Bus
- Wiring-free module interconnect scheme
- Standard CubeSat Kit PCB footprint
- 2-layer blue-soldermask PCB



ORDERING INFORMATION

Pumpkin P/N 711-00338

Option Code	Configuration
/00 (standard)	normal capacity (2 batteries)
/01	high capacity (4 batteries)

Contact factory for availability of optional configurations.
Option code /00 shown.



CAUTION

Electrostatic
Sensitive
Devices

Handle with
Care



¹ An alternate configuration with 4 iPod® batteries is also available.

² The 104-pin CubeSat Kit Bus was introduced with the Rev C FM430 architecture. The 104-pin CubeSat Kit Bus is generally backwards-compatible with the earlier 80-pin CubeSat Kit Bus. Consult documentation for more information.

³ Planned future software enhancement.

ABSOLUTE MAXIMUM RATINGS

Parameter	Symbol	Value	Units
Operating temperature ⁴	T_A	-40 to +85	°C
Maximum battery voltage ⁵	V_{BATT_MAX}	10	V
Maximum battery current ⁶	I_{BATT_MAX}	1.5	A

JUMPER SETTINGS

Name	Function	Default Setting
JP1	Connect Battery A's – terminal to s0 (RBF switch).	connected
JP2	Connect Battery B's + terminal to s4 (RBF switch).	connected
JP3	Connect batteries in series (to override RBF switch functioning as battery disconnect).	disconnected
JP4	Connect Battery A's + terminal to s1 (Deployment switch).	connected
JP5	Connect regulator inputs to s5 (Deployment switch).	connected
JP6	Connect battery output to regulator inputs (to override Deployment switch functioning as load disconnect).	disconnected

WARNING: Exercise care when installing or replacing iPod batteries and setting jumpers **JP1-JP6**. Large currents may be present.

Please note the following. Refer to schematics for more detail.

- **Battery ground lift / connect.** Jumpers **JP1**, **JP2** and **JP3** control how the two iPod® batteries are connected in series. For a connection through the CubeSat Kit's Remove-Before-Flight switch, connect only **JP1** and **JP2**, leaving **JP3** disconnected. This is the default configuration and allows the user to disable the batteries via the Remove-Before-Flight Pin. For a direct connection to bypass the Remove-Before-Flight switch⁷, connect **JP3** (and optionally disconnect **JP1** and **JP2**).
- **Battery power connect / disconnect:** Jumpers **JP4**, **JP5** and **JP6** control how the series batteries are routed to the LDO regulators' inputs. For a connection through the CubeSat Kit's Deployment switch, connect only **JP4** and **JP5**, leaving **JP6** disconnected. This is the default configuration and allows the user to turn the entire CubeSat Kit module stack on and off via the Deployment switch when the batteries are connected via the removal of the Remove-Before-Flight pin. For a direct connection, connect **JP6** (and optionally disconnect **JP4** and **JP5**).

WARNING: Under no circumstances should the iPod® batteries used with the Linear EPS be altered in any way. In particular, the overcurrent, overvoltage and undervoltage protection circuits that are supplied with every iPod® battery *must not be removed under any circumstances*, for doing so would present a serious fire hazard. The design of the Linear EPS requires that these protection circuits be in place at all times.

⁴ For on-board electronics. Temperature limits for batteries chosen by user are likely to be much narrower.

⁵ Applied to CubeSat Kit bus V_{BATT} signal.

⁶ Charge and discharge. Limited by a internal fuses in iPod® batteries.

⁷ E.g. in order to run the Linear EPS outside of a CubeSat Kit.

PHYSICAL CHARACTERISTICS

Parameter	Conditions / Notes	Symbol	Min	Typ	Max	Units
Mass	With option /00			155		g
	With option /01			210		
Height of components above PCB	With option /00				14	mm
	With option /01				24	
Height of components below PCB ⁸					2	mm
PCB width	Corner hole pattern matches PC/104			96		mm
PCB length				90		mm
PCB thickness				1.6		mm

SIMPLIFIED MECHANICAL LAYOUT⁹

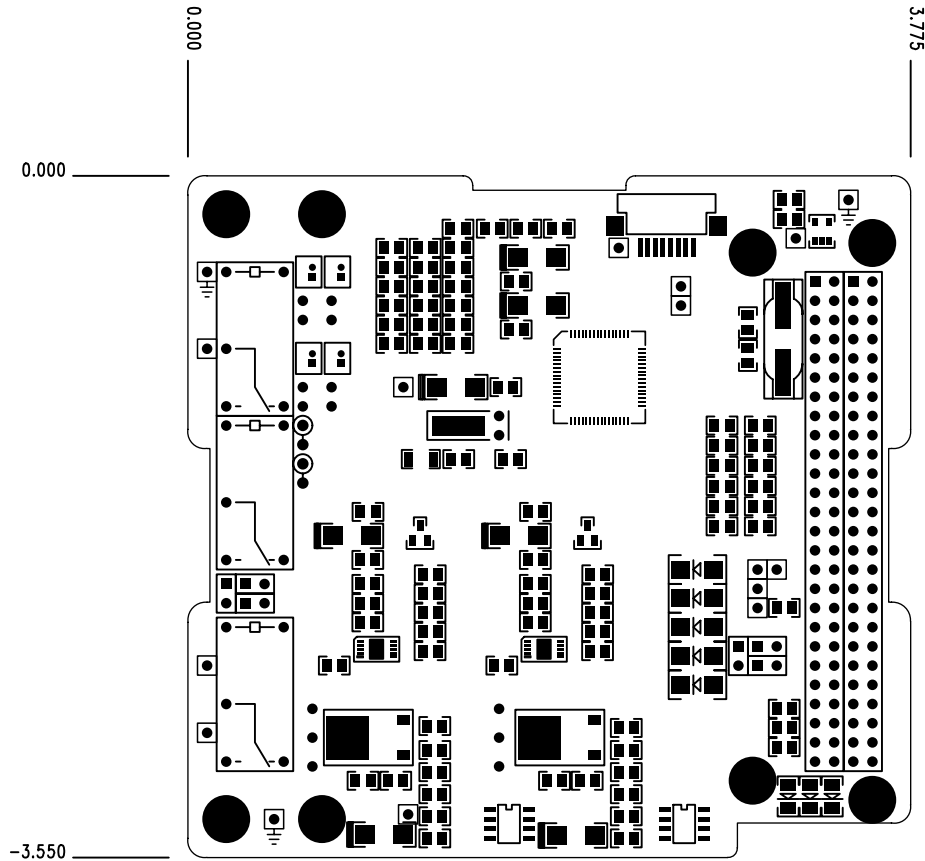

⁸ Does not include length of PC/104 stackthrough header pins (H1 & H2) of 10.4mm.

⁹ Dimensions in inches. Batteries and battery tray not shown.

ELECTRICAL CHARACTERISTICS

(T = 25°C, +5V bus = +5V unless otherwise noted)

Parameter	Conditions / Notes	Symbol	Min	Typ	Max	Units
+5V LDO output		V_{+5V_SYS}		5.0		V
+3.3V LDO output		V_{VCC_SYS}		3.3		V
Quiescent current	$I_{OUT} = 0mA$, processor asleep	I_{Q_OFF}		150		μA
	$I_{OUT} = 0mA$, processor active	I_{Q_ON}		2		mA
Overcurrent trip point for output to CubeSat Kit Bus		I_{TRIP_VBATT}		1500		mA
		I_{TRIP_+5V}		1000		
		I_{TRIP_VCC}		500		
Total battery energy storage	With option /00			11		Wh
	With option /01			22		
USB current draw				450	500	mA
Battery recharge time	With option /00			12		h
	With option /01			24		
Battery auto-disconnect voltage	Per battery. Implemented via each battery's own internal protection device			2.7		V

BLOCK DIAGRAM

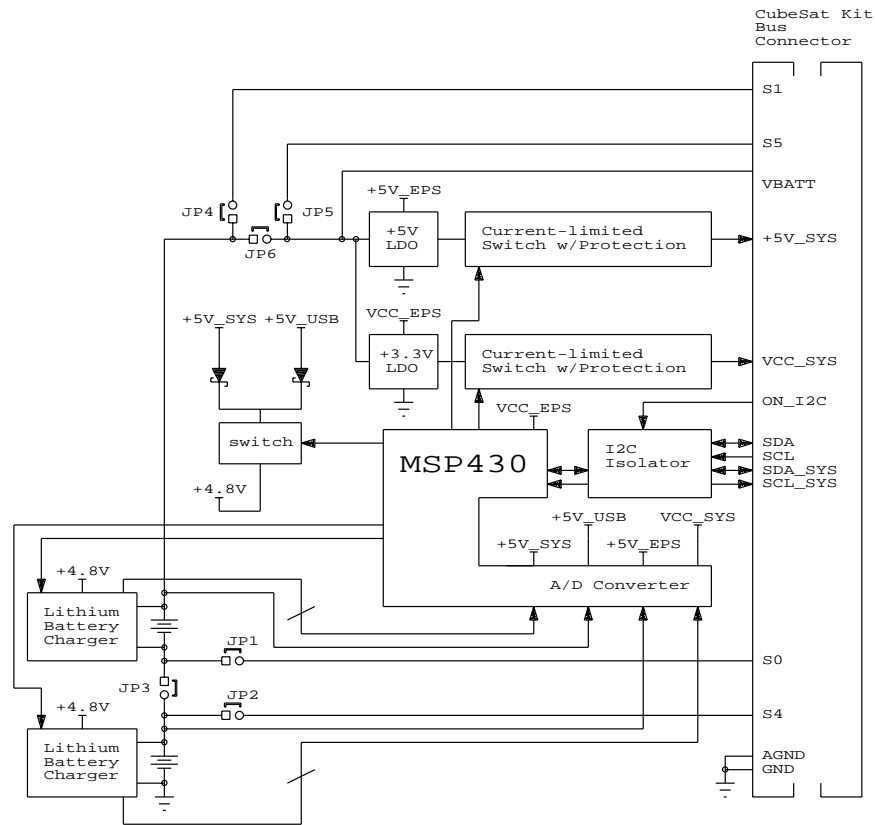

CubeSat Kit Bus PIN DESCRIPTIONS

CubeSat System Bus

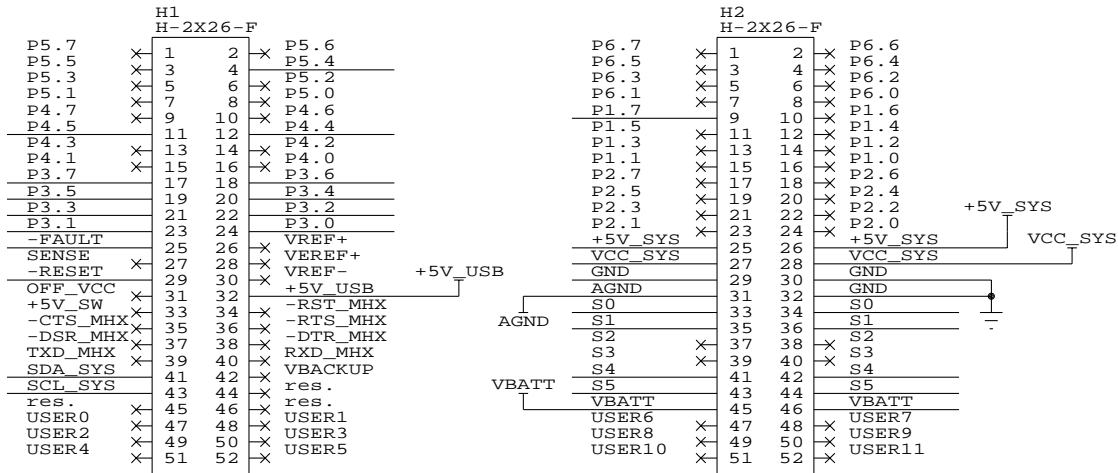

CubeSat Kit Bus PIN DESCRIPTIONS – MSP430 I/O Port 1

Name	Pin	I/O	Description
P1.0	H2.16		Not used.
P1.1	H2.15		Not used.
P1.2	H2.14		Not used.
P1.3	H2.13		Not used.
P1.4	H2.12		Not used.
P1.5	H2.11		Not used.
P1.6	H2.10		Not used.
P1.7	H2.9	O	Not normally used. When R9 is fitted, can be used as -ON_USB to CSK Bus.

CubeSat Kit Bus PIN DESCRIPTIONS – MSP430 I/O Port 2

Name	Pin	I/O	Description
P2.0	H2.24		Not used.
P2.1	H2.23		Not used.
P2.2	H2.22		Not used.
P2.3	H2.21		Not used.
P2.4	H2.20		Not used.
P2.5	H2.19		Not used.
P2.6	H2.18		Not used.
P2.7	H2.17		Not used.

CubeSat Kit Bus PIN DESCRIPTIONS – MSP430 I/O Port 3

Name	Pin	I/O	Description
P3.0	H1.24	O	Not normally used. When R11 is fitted, can be used as -CS_SD/ON_I2C to CSK Bus.
P3.1	H1.23	O	Not normally used. When R16 is fitted, can be used as MOSI (SPI data out) to CSK Bus.
P3.2	H1.22	I	Not normally used. When R17 is fitted, can be used as MISO (SPI data in) from e.g. the SD card on FM430.
P3.3	H1.21	O	Not normally used. When R18 is fitted, can be used as SCLK (SPI clock) to e.g. CSK Bus.
P3.4	H1.20	O	Not normally used. When R12 is fitted, can be used as Tx0 (async serial data out) to CSK Bus.
P3.5	H1.19	I	Not normally used. When R13 is fitted, can be used as Rx0 (async serial data in) from CSK Bus.
P3.6	H1.18	O	Not normally used. When R14 is fitted, can be used as Tx1 (async serial data out) to CSK Bus.
P3.7	H1.17	I	Not normally used. When R15 is fitted, can be used as Rx1 (async serial data in) from CSK Bus.

CubeSat Kit Bus PIN DESCRIPTIONS – MSP430 I/O Port 4

Name	Pin	I/O	Description
P4.0	H1.16		Not used.
P4.1	H1.15		Not used.
P4.2	H1.14		Not used.
P4.3	H1.13		Not used.
P4.4	H1.12	O	Not normally used. When R10 is fitted, can be used as a general-purpose output to CSK Bus.
P4.5	H1.11	O	Not normally used. When configured as an output, can be used as -ON_SD (enable SD card power on FM430) to CSK Bus.
P4.6	H1.10		Not used.
P4.7	H1.9		Not used.

CubeSat Kit Bus PIN DESCRIPTIONS – MSP430 I/O Port 5

Name	Pin	I/O	Description
P5.0	H1.8		Not used.
P5.1	H1.7		Not used.
P5.2	H1.6		Not used.
P5.3	H1.5		Not used.
P5.4	H1.4	O	Not normally used. When configured as an output, can be used as CLK OUT (enable SD card power on FM430) to CSK Bus.
P5.5	H1.3		Not used.
P5.6	H1.2		Not used.
P5.7	H1.1		Not used.

CubeSat Kit Bus PIN DESCRIPTIONS – MSP430 I/O Port 6

Name	Pin	I/O	Description
P6.0	H2.8		Not used.
P6.1	H2.7		Not used.
P6.2	H2.6		Not used.
P6.3	H2.5		Not used.
P6.4	H2.4		Not used.
P6.5	H2.3		Not used.
P6.6	H2.2		Not used.
P6.7	H2.1		Not used.

CubeSat Kit Bus PIN DESCRIPTIONS – Analog References

Name	Pin	I/O	Description
VREF+	H1.26		Not used.
VREF-	H1.30		Not used.
VEREF+	H1.28		Not used.

CubeSat Kit Bus PIN DESCRIPTIONS – I2C Bus

Name	Pin	I/O	Description
SDA_SYS	H1.41	I/O	Not normally used. When R65 is fitted, can be used as a isolated I2C data line under control of -CS_SD/ON_I2C from CSK Bus.
SCL_SYS	H1.43	O	Not normally used. When R71 is fitted, can be used as a isolated I2C clock line under control of -CS_SD/ON_I2C from CSK Bus.

CubeSat Kit Bus PIN DESCRIPTIONS – Control & Status

Name	Pin	I/O	Description
-FAULT	H1.25	I	Input to Linear EPS processor.
SENSE	H1.27		Not used.
-RESET	H1.29	I	Input to reset supervisor on Linear EPS. Removal of R1 disables this connection and isolates reset supervisor on Linear EPS.
OFF_VCC	H1.31		Not used.

CubeSat Kit Bus PIN DESCRIPTIONS – RBF and Deployment Switches

Name	Pin	I/O	Description
S0	H2.33 H2.34	-	Battery isolation terminal. Connected to battery A's - terminal when jumper JP1 is fitted.
S1	H2.35 H2.36	-	Battery power disconnect terminal. Connected to battery A's + terminal when jumper JP4 is fitted.
S2	H2.37 H2.38		Not used.
S3	H2.39 H2.40		Not used.
S4	H2.41 H2.42	-	Battery isolation terminal. Connected to battery B's + terminal when jumper JP2 is fitted.
S5	H2.43 H2.44	-	Battery power disconnect terminal. Connected to LDO regulator input terminals when jumper JP5 is fitted.

CubeSat Kit Bus PIN DESCRIPTIONS – Power

Name	Pin	I/O	Description
VBATT	H2.45 H2.46	I/O	Battery voltage. Connected to battery A's + terminal. Can be used to sense battery voltage and/or to charge battery from an external source (e.g. solar cells).
+5V_USB	H1.32	I	Source for charging batteries via USB.
+5V	H2.25 H2.26	O	+5V system power from LDO regulator.
+5V_SW	H1.33		Not used.
VBACKUP	H1.42		Not used.
VCC_SYS	H2.27 H2.28	O	+3.3V system power from LDO regulator.
AGND	H2.31		Analog ground. Connected to digital ground on Linear EPS via 0Ω R5.
GND	H2.29 H2.30 H2.32	–	Digital ground.

CubeSat Kit Bus PIN DESCRIPTIONS – Transceiver Interface

Name	Pin	I/O	Description
-RST_MHX	H1.34		Not used.
-CTS_MHX	H1.35		Not used.
-RTS_MHX	H1.36		Not used.
-DSR_MHX	H1.37		Not used.
-DTR_MHX	H1.38		Not used.
TXD_MHX	H1.39		Not used.
RXD_MHX	H1.40		Not used.

CubeSat Kit Bus PIN DESCRIPTIONS – User-defined

Name	Pin	I/O	Description
USER0	H1.47		Not used.
USER1	H1.48		Not used.
USER2	H1.49		Not used.
USER3	H1.50		Not used.
USER4	H1.51		Not used.
USER5	H1.52		Not used.
USER6	H2.47		Not used.
USER7	H2.48		Not used.
USER8	H2.49		Not used.
USER9	H2.50		Not used.
USER10	H2.51		Not used.
USER11	H2.52		Not used.

CubeSat Kit Bus PIN DESCRIPTIONS – Reserved

Name	Pin	I/O	Description
res.	H1.44	–	Reserved for future use.
res.	H1.45	–	Reserved for future use.
res.	H1.46	–	Reserved for future use.

REGULATOR EFFICIENCY

The Linear EPS is designed to provide low-noise +5V and +3.3V power to a stack of CubeSat Kit modules. It uses linear low-dropout (LDO) regulators with built-in overcurrent, overvoltage and reverse voltage protection. Linear switching regulators have no noise, but are inefficient because of the unavoidable voltage drop across the pass element of the regulator.

iPod BATTERIES

The Linear EPS accepts the standard Li-Poly battery for 1st and 2nd-generation iPods on a dedicated battery tray. Each battery measures 3.2 x 50 x 85mm and uses a standard 2-pin connector. The underside of the Linear EPS PCB is a ground plane without any components or protrusions over an area larger than 50 x 85mm. The ground plane also serves as a heatsink for the regulators and battery chargers.

A simple test with the Linear EPS configured with two iPod batteries (11Wh), a Pumpkin Rev C FM430 Flight Module and a MaxStream® 900MHz 9XStream transceiver at 100mW output power resulted in approximately 24 hours of runtime before the batteries were exhausted.

The batteries are user-replaceable. Due to variances in the connectors supplied with iPod batteries, iPod battery connectors are replaced at the factory with Hirose DF13-series connectors to ensure good battery connections.

FITMENTS IN MODULE STACK

The Linear EPS can be placed in a CubeSat Kit module stack with an MHX-series transceiver or equivalent fitted directly beneath it.

The Linear EPS with option /01 requires a full 25mm of free height above it to fit within a CubeSat Kit module stack.

MULTIPLE POWER SUPPLY ISSUES

The Linear EPS provides both +5V and +3.3V supplies to the CubeSat Kit Bus, without regard for whether other sources (e.g., CubeSat Kit Development Boards) are also simultaneously feeding +5V to +5V_5XS and/or +3.3V to VCC_5XB on the CubeSat Kit Bus. No problems with any CubeSat Kit hardware have been observed. Users should take the standard precautions to avoid any potential damage to unpowered linear regulators subjected to large voltages at their outputs, etc.

BATTERY RECHARGING

The Linear EPS is designed to be charged when installed as part of a stack of modules in a CubeSat Kit. Charging at C/8 begins immediately upon connecting the CubeSat Kit to a powered USB host capable of sourcing 500mA. When charging begins, each battery on the Linear EPS is automatically isolated from the load and is charged individually via a dedicated Lithium cell chemistry battery charger. Also, each LDO regulator is disconnected from the Bus at this time.

Charging can be substantially accelerated (to C/2) by connecting a +5V source to the CubeSat Kit via the external +5V connector when USB is connected.

Charging status is indicated by three LEDs on the Linear EPS when active USB is connected:

LEDs blinking	Charging Status
none	Unspecified error.
1	First stage (constant-current) charging.
2	Second stage (constant-voltage) charging.
3	Third stage charging. Charging is complete.

OPERATING FROM BATTERIES

Once it is disconnected from an active USB source, and the Remove-Before-Flight and Deployment switches connect the batteries to each other and to the load, the Linear EPS automatically switches over to provide unregulated and current-limited battery power as well as regulated and current-limited +5V and +3.3V to the CubeSat Kit Bus. Power will be delivered until the batteries are exhausted – at which point they will automatically disconnect themselves from the load – or until charging commences via USB.

While running from batteries, the Linear EPS indicates the status of its batteries via LEDs that flash once a second. All battery life indications are approximations based on battery voltage and will vary based on battery age, last charge, load, etc.

LEDs flashing	Battery Status
none	Batteries are exhausted.
1	Batteries have approximately 25% of their capacity remaining.
2	Batteries have approximately 50% of their capacity remaining.
3	Batteries have over 75% of their capacity remaining.

USER PROGRAMMABILITY

Users can reprogram the Linear EPS using the source code (provided), a CubeSat Kit FM430 Programming adapter, an MSP430 Flash Emulation Tool and a compatible MSP430 IDE.

MODULE STACKING

More than one Linear EPS can be used simultaneously to discharge into a load, or to be charged via USB. In this configuration, each Linear EPS operates independently. Equal current sharing from each battery and each output is not guaranteed due to the nature of the LDOs and current switches employed ... however, tests conducted with identical batteries from the same manufacturer and at the same state of charge (SOC) reveal that the currents are shared reasonably equally across all outputs.¹⁰

For best results and battery equalization, multiple stacked Linear EPS should be charged and discharged together. Multiple stacked Linear EPS should not be operated with distinctly different battery SOC's.

With stacked modules, it is recommended that charging always be accomplished with an external +5V source present (see Battery Recharging, above), so as to take advantage of the fast battery recharging mode, and so as not to exceed the USB host's 500mA limit.

¹⁰ I.e., it is possible to get over 2000mA of regulated +5V and over 1000mA of regulated +3.3V from a pair of stacked Linear EPS.

TRADEMARKS

The following are Pumpkin trademarks. All other names are the property of their respective owners.

- Pumpkin™ and the Pumpkin logo
- Salvo™ and the Salvo logo
- CubeSat Kit™ and the CubeSat Kit logo

DISCLAIMER

PUMPKIN RESERVES THE RIGHT TO MAKE ANY CHANGES WITHOUT FURTHER NOTICE TO ANY PRODUCTS HEREIN TO CORRECT ERRORS AND IMPROVE RELIABILITY, FUNCTION, APPEARANCE OR DESIGN. PUMPKIN DOES NOT ASSUME ANY LIABILITY ARISING OUT OF THE APPLICATION OR USE OF ANY PRODUCT OR CIRCUIT DESCRIBED HEREIN; NEITHER DOES IT CONVEY ANY LICENSE UNDER ITS PATENT RIGHTS, NOR THE RIGHTS OF OTHERS.



744 Naples Street
San Francisco, CA 94112 USA
tel: (415) 584-6360
fax: (415) 585-7948

web: <http://www.pumpkininc.com/>
email: info@pumpkininc.com

web: <http://www.cubesatkit.com/>
email: info@cubesatkit.com