

EE 231 Lab 0

Wire Wrapping Project: Counter Board

In this experiment, you will build a simple counter circuit that can be plugged into your breadboard. It will provide a set of TTL output signals at various frequencies for use as clock inputs or other applications. The design of this board is simple and compact. It will be built on a piece of perf board (a modular circuit board with pre-drilled holes) with a row of pins for easy connection to jumper wires or breadboards. Connections will be made using the wire-wrapping technique

This circuit is centered around the 74HC4040 ripple counter whose outputs divide the input signal by two for each successive output. There are 12 outputs, so the slowest output is the input frequency divided by 2^{12} . By using two ripple counters, we will build it such that you will be able to select from several different ranges of frequencies. The input clock source comes from a 1 MHz oscillator fed through a Schmitt trigger for a clean TTL signal.

1. Layout:

The perf board will provide the structure to construct the circuit. Each of the components will be tacked onto the board then connections will be made with wrapped wires on the back side. We will use pin headers both to provide connection points for power, ground, and outputs, and also to make a jumper bank for selecting the speed of the outputs.

2. Design:

This design uses an oscillator crystal to generate a 1MHz square wave that is passed through a Schmitt trigger to ensure the signal has square edges. The output of the Schmitt trigger is sent to the 4x2 pin header and to the clock input of one of the ripple counters. The four connections to one side of the 4x2 pin header are the output of the Schmitt trigger and the 4th, 8th, and 12th outputs of the first ripple counter. These are used to feed varying clock speeds into the second ripple counter, thus controlling the frequency options for final output of the circuit. On the other side of the 4x2 header, all four pins connect to the input of the second ripple counter, such that when you move the jumper block from one pin pair to the next, you are adjusting the input to the second ripple counter. The first pair of pins makes a direct connection from the oscillator/Schmitt trigger making a 1 MHz input to the second ripple counter. The second pair uses the 4th output of the first counter, scaling the 1MHz oscillator to an intermediate frequency of 62.5 KHz, the third pair uses the 8th output scaling the intermediate signal to 3.9 KHz, and the fourth pair uses the 12th output scaling the intermediate signal to 244 Hz (the fourth pair). Each of these can be used to feed the input of the second 74HC4040 counter thus scaling the outputs by 2^4 for each subsequent jumper position.

1. Lab Instructions

1.1 Layout

Choose a layout that places the components on the board in a logical arrangement and has the jumper pins on the opposite end from the bent pin header. A sample layout is provided for efficient design. Follow this layout to be sure all your components will fit and the circuit will be easiest to use.

1. To create the 4x2 pin header, we need to combine two 4x1 headers broken off the large array in your kit, they simply snap apart between pins (try to use a needle-nose pliers to be sure it breaks in the right place). We will use a jumper block to make the necessary connections. The two 4x1 pin headers will need to be placed in parallel to each other so that the jumper block connects together one pin from each of the headers, as shown in Figure 1.

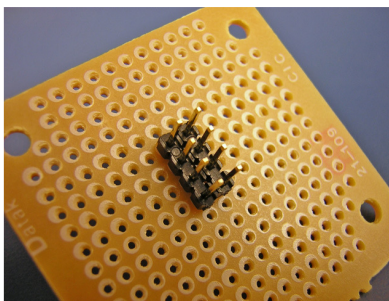

Figure 1. Pin Headers for Jumper

2. Leave one blank row of holes between each component and its neighbor.
3. The right-angle pin header is provided to easily connect the board to your breadboard and needs to protrude over the edge of the proto board, as depicted in Figure 2.
4. Make sure that the power and ground pins of the IC's are not reversed as this will make them operate incorrectly or destroy them.

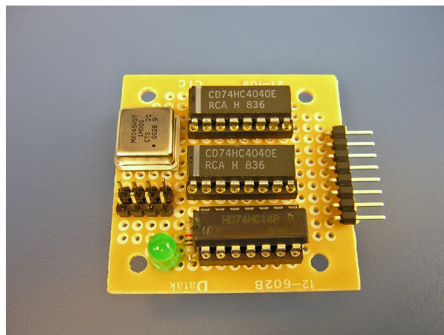

Figure 2. Sample Layout

1. Tack Soldering

All of the parts need to be tack soldered onto the proto board to keep them from shifting while wire wrapping, as shown in Figure 3. Here we are simply using solder as a means of mechanical attachment, not as an electrical connection.

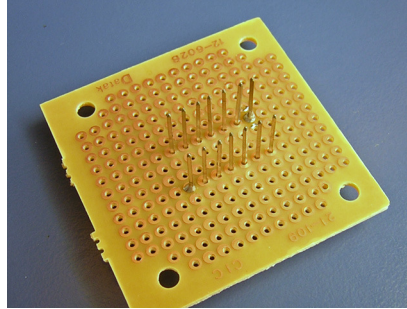

Figure 3. Sample Tack Soldering

1. When tack soldering, the goal is to temporarily attach the parts to the board so they can be wire wrapped. All parts should be tack soldered to the board but only the ones that easily come off must be tack soldered. To tack solder something just put enough solder to hold the part onto the board without impeding the wire wrap tool's ability to wrap around the pin.
2. Be careful, the soldering iron is very hot.
3. After tack soldering the parts, install the pin ID labels, these help you easily identify the pin numbers on the bottom of the board.

2. Wire Routing

Figure 4 shows a wiring schematic. Look at your wiring schematic and consider where to run each wire. The wires need to be routed so that they are as short as possible yet as low density as possible (try to spread the wires out on the board rather than running them all through the same place). In general it is best to use the wide empty space between pin rows to run the wires, rather than running them between the pins where there is less space.

1. Refer to the separate Wire Wrapping Tutorial for instructions on the process.
2. Run all the wires for a single part or all the wires that connect together at the same time to reduce the chance for forgotten wires.
3. Use the logical color scheme for the wires. For example, red for power and black for ground. If you use one color wire for all the power and ground line, do not use that color for any other connection to prevent later confusion or cross-wiring. Organization is important to making the wires easy to trace.
4. Six color of wire are available: red, black, white, blue, yellow, green.
5. Remember that when looking at the board from the bottom the pins are not in the same order that they are when looking from the top, this is why the ID

labels are important.

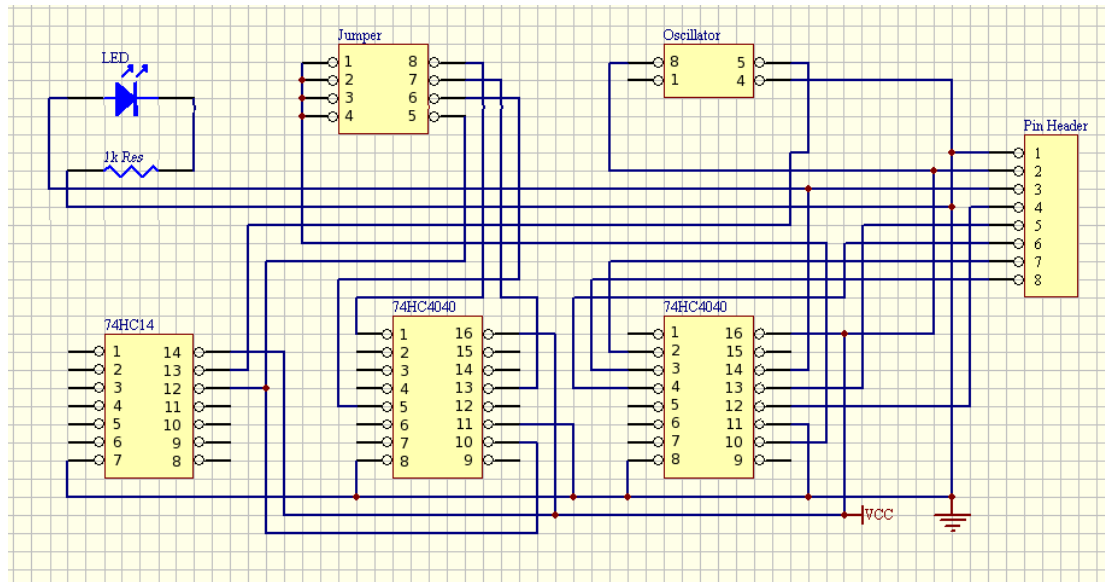

Figure 4. Sample Schematic

3. Other Considerations

- The LED is provided to show the output of the slowest counter output. It needs to be hooked up in series with the resistor and the combination connected between the output and ground.
- Testing of the completed board is required! Using a logic analyzer or multimeter with frequency setting will display what speed each of the output pins is running at. You can also use the logic probe for slower clock speeds. Confirm that each of the jumper settings changes the speed of the outputs and that the outputs are operating at the expected speeds.
- After testing the board and confirming its accuracy, it is a good idea to trim the pins. The pins are long to facilitate wrapping wires around them. Once wrapping is complete, the pins can be trimmed to make the board take up less space. Use wire cutters to clip off the ends of the pins. Protect your eyes and clean up after yourself. Be sure you don't send pins flying around the room.
- Reminder: When your project is completed, the pins on front and back are exposed and live in the circuit. Use care in what you allow them to touch while the circuit is running, it would be easy to create a short circuit.