

EE 308
Exam 3
April 19, 2000

Name: _____

You may use any of the Motorola data books and notes from the Web. Show all work. Partial credit will be given. No credit will be given if an answer appears with no supporting work.

For all problems assume you are using a MC68HC912B32 with an 16-MHz crystal, resulting in an 8-MHz processor clock.

1. A 68HC12 is operating in expanded mode, with external memory from 0x1000 to 0x7fff. The memory contents in address 0x1000 through 0x100f are shown below.

	0	1	2	3	4	5	6	7	8	9	A	B	C	D	E	F
1000	10	23	3B	7C	10	04	86	80	B7	10	25	3B	FC	10	18	F3

Show what will be on the address/data bus and the control lines when the HC12 executes the following instructions:

- (a) Reads a byte from address 0x1001.

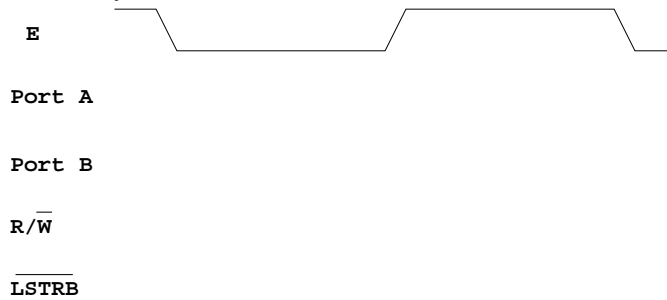

- (b) Writes a 0x55aa to the two bytes at addresses 0x1002 and 0x1003.

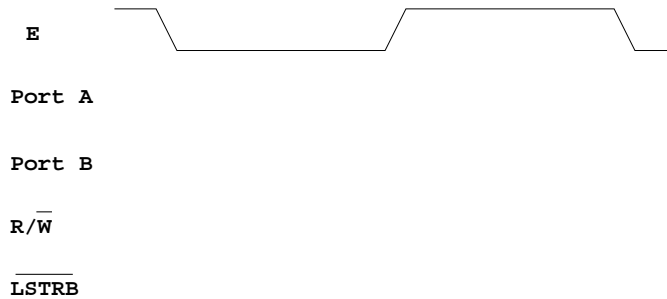

- (c) How do you set up the HC12 to have 2 E-clock stretches for external accesses? Write some C code to do this.

- (d) Sketch the E-clock with 2 E-clock stretches. Indicate the length of time E is low, and the length of time E is high.

2. A new startup company designs a series of peripheral chips they call the Super Terrific Universal Peripheral Interface Device (STUPID) chips. The figure below shows two STUPID chips connected to an HC12. One is an input chip, the other is an output chip.

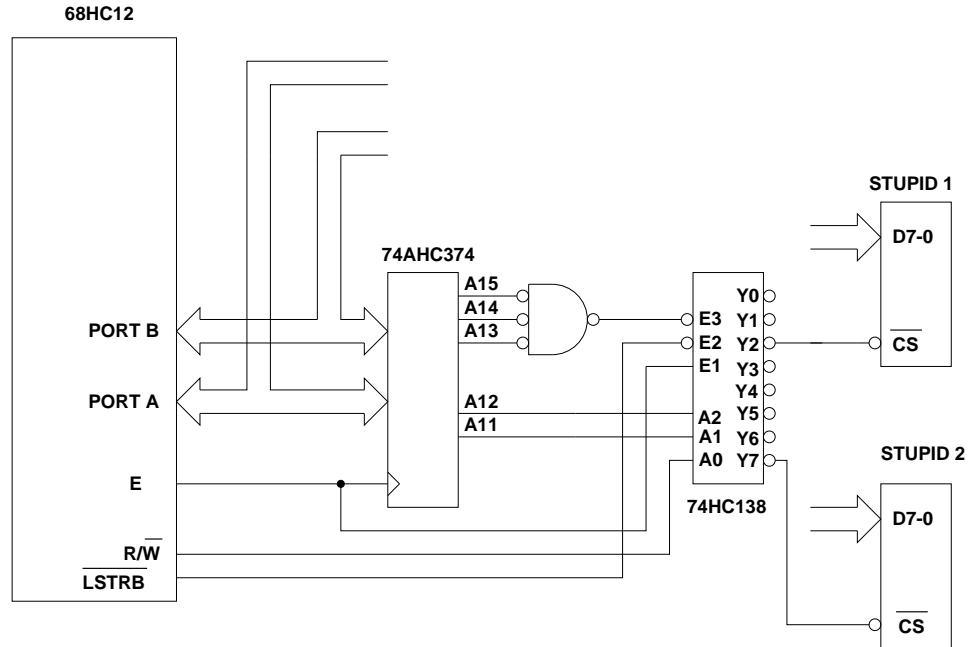

STUPID OUTPUT BUS TIMING

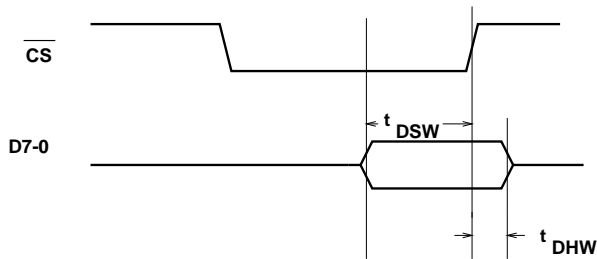

$t_{DSW} = 40 \text{ ns Min}$ Data Setup Time, Write
 $t_{DHW} = 5 \text{ ns Min}$ Data Hold Time, Write

- (a) What range of addresses will select STUPID 1 chip? Is it an input chip or an output chip.

- (b) Should D7-0 of STUPID 1 be connected to Port A or Port B? Why?

- (c) What range of addresses will select STUPID 2 chip? Is it an input chip or an output chip.
- (d) Should D7-0 of STUPID 2 be connected to Port A or Port B? Why?
- (e) Is t_{DSW} for the output chip compatible with the 68HC12? Why or why not? What is the corresponding time for the 8 MHz 68HC12?
- (f) Is t_{DHW} for the output chip compatible with the 68HC12? Why or why not? What is the corresponding time for the 8 MHz 68HC12?
- (g) Explain in words what t_{DSW} means.
- (h) Write some C code to write an 0x55 to the output STUPID chip.

3. The figure below shows an SOTC-001 Super Oven Temperature Controller connected to a 68HC12 by its SPI. The SOTC-001 works in the following manner: the HC12 selects the SOTC-001, then sends it an 8-bit number (from 0° C to 255° C) which tells the SOTC-001 what temperature to set the oven at. It then reads a byte from the SOTC-001, which tells the HC12 the actual temperature of the oven. The HC12 then deselects the SOTC-001. The figure shows the SPI timing information. The maximum SCK the SOTC-001 can use is 250 kHz.

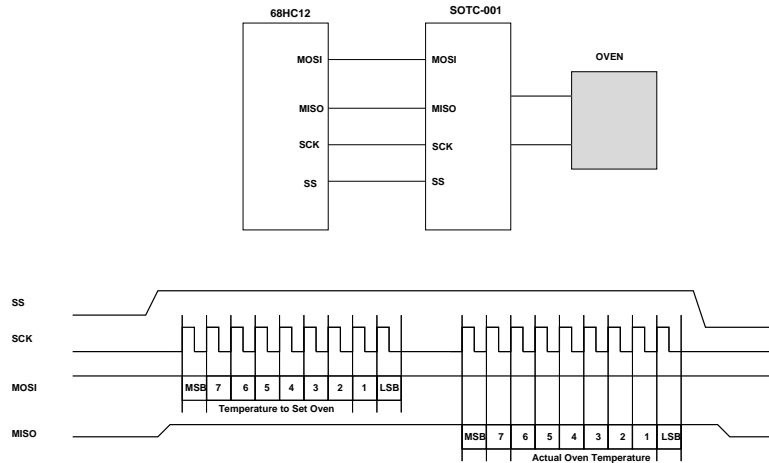

- (a) How do you clear the SPI flag?

- (b) Write some C code to set up the 68HC12 SPI for use with the SOTC-001. To insure as much credit as possible, explain how you set up each register.

- (c) Write some C code to set the oven temperature at 198° C, read the actual oven temperature, and assign it to a variable called temp.