

EE 308 – LAB 10

Serial Communications using the HC12 SPI and the MAX522 D/A Converter

For the prelab, write the program for Part 4 of this lab.

In this lab you will use the HC12 SPI serial interface to communicate with a serial D/A converter and with another HC12. You will use the on-board A/D converter to read a voltage from a potentiometer, and reproduce that voltage with the D/A converter. You will also send the voltage (as a digital number) over the SPI to a neighbor's HC12. Your neighbor will display the voltage on his/her LEDs and on the terminal.

1. Put the parts on your board for using a MAX522 D/A converter chip. The attached layout diagram shows one way to put the parts on your board. The attached schematic shows how to wire the project. In lab you will be given the tools and instructions on how to do this.
2. Before putting the D/A chip into your socket, verify that there are 5 volts at pins 3 and 7 of the eight-pin socket, and that pin 4 is connected to ground. Get a MAX522 D/A chip, make sure power is turned off on your HC12 board, and plug the D/A converter into the eight-pin socket.
3. Use DDebug12 to verify that you can generate analog voltages from the D/A converter. You can set up the SPI by writing the appropriate values to the SPI control registers. Then select the D/A converter (by bringing the \overline{SS} line low), write the value to the D/A converter to tell it to generate an output voltage (e.g., 1.0 V on OUTA), and deselect the D/A. Make sure both channels of the D/A work.
4. Connect a potentiometer to one of your A/D inputs, as you did in Lab 9. Write a program to read the voltage from the A/D, write the value to the D/A, and display it on the terminal. Do this at a rate of about 4 times a second, using an RTI interrupt.
5. Connect the appropriate SPI and slave select pins to your logic analyzer, and capture a transfer over the SPI. Verify that the clock frequency, phase and polarity match the values you programmed them for. Decode the serial data stream for the transfer to the D/A converter and to the slave HC12, and make sure these are the values you expected.
6. Get together with one of your neighbors in the lab. One of you should set up your SPI as a master, and the other as a slave.
 - Connect the master and slave MOSI and SCK lines of the two HC12s together.
 - Connect a signal from a general purpose I/O pin on the master to the \overline{SS} line on the slave.
 - Connect the 8 PORTA pins of the slave HC12 to the LEDs on a breadboard.
 - For the master HC12, use the program from Part 4. Add to this program some code to select the slave HC12 and send it the value it writes to the MAX522 D/A converter.
 - For the slave HC12, write a program which puts the SPI into slave mode, with the same serial protocol as used by the master. Write a simple loop in the main program which waits until the master HC12 sends the slave HC12 data over the SPI. Read the data from the SPI data register, and display the value on the LEDs connected to PORTA.

Verify that value displayed on the LEDs connected to the slave agree with the voltage on the potentiometer.

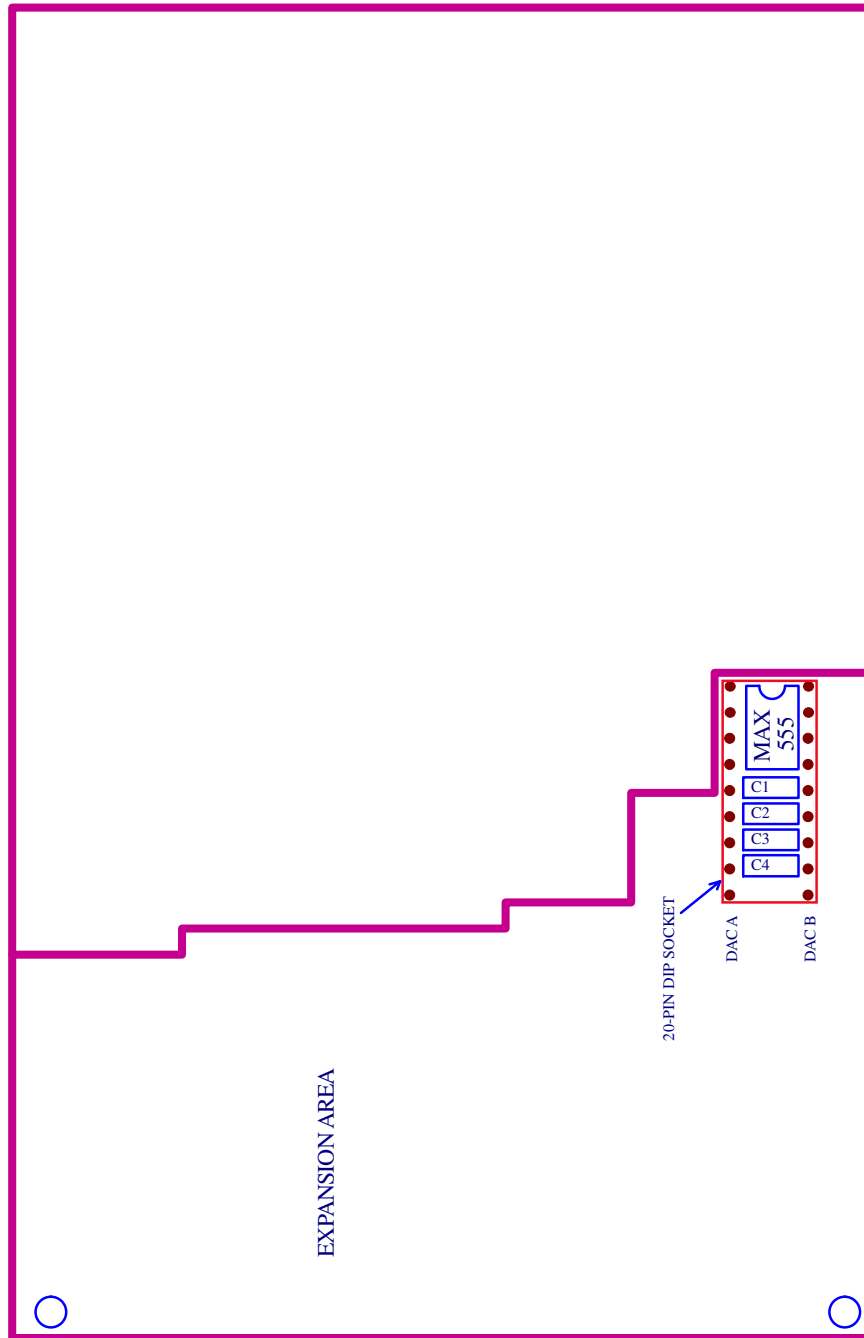

Figure 1. Diagram showing where to put the MAX522 and associated capacitors on the HC12 EVB. You will put a 20-pin DIP socket on the board to hold the MAX522 and the capacitors. On the reverse side you will make the connections shown in the schematic of Figure 2 using wire-wrapping. Note: There is a row of pins called V_{DD} next to the area where the 20-pin DIP socket goes. Do not put the dip socket into any of the holes labeled V_{DD} .

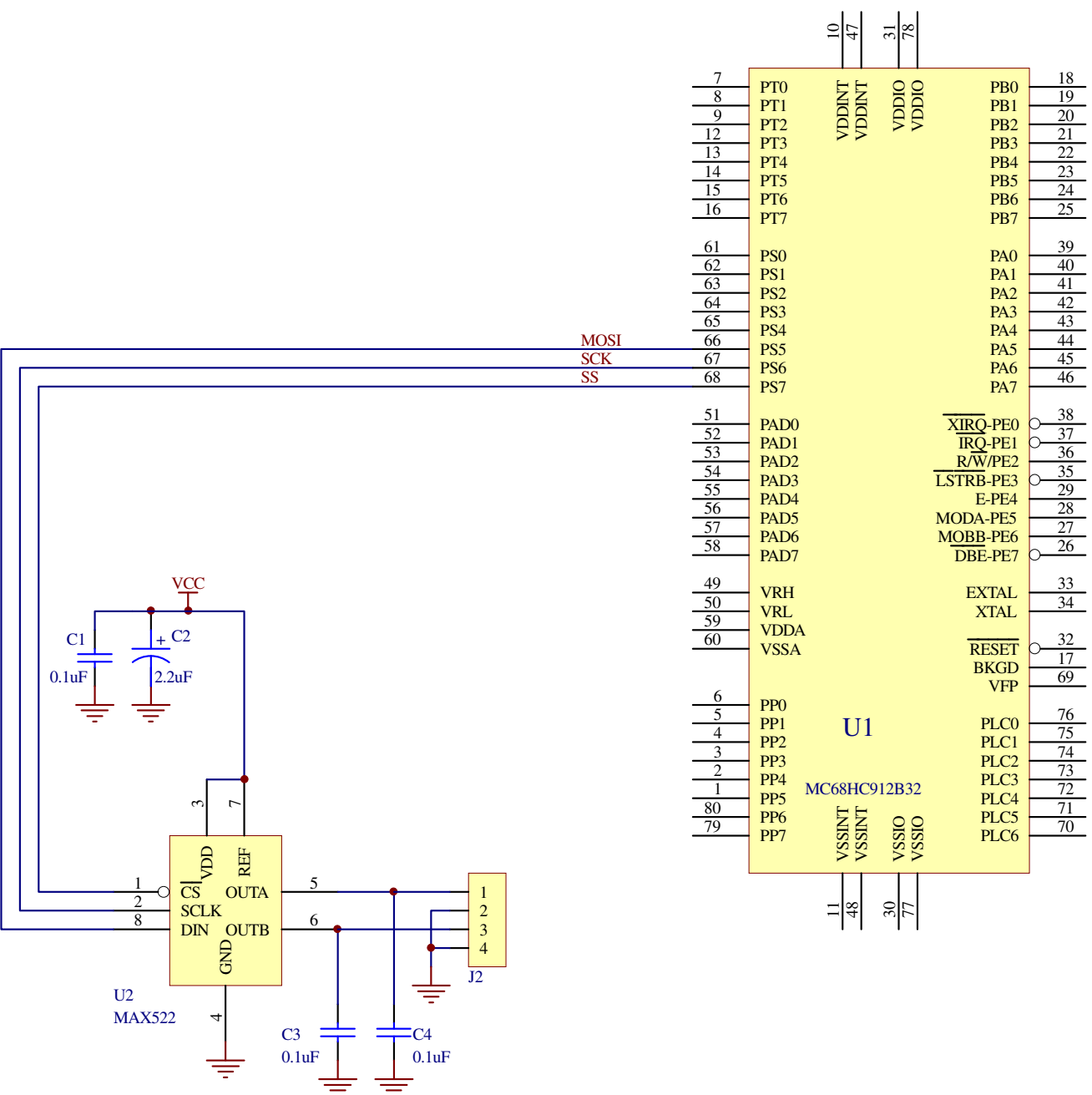

Figure 2. Schematic showing how to build the circuit to add the MAX522 D/A converter to your EVB.