

## Using MSI Logic To Build An Output Port

- Many designs use standard MSI logic for microprocessor expansion
- This provides an inexpensive way to expand microprocessors
- One MSI device often used in such expansions is a decoder, such as the 74HC138 decoder chip

### 74HC138

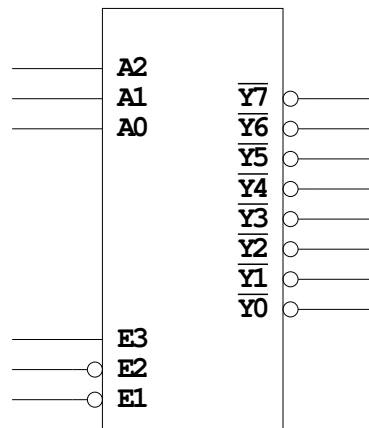

When E3 high, E2 and E1 low, one of the outputs of the 74138 will go low  
A2, A1, A0 determine which output will be low.

A2	A1	A0	Output
0	0	0	Y0
0	0	1	Y1
0	1	0	Y2
0	1	1	Y3
1	0	0	Y4
1	0	1	Y5
1	1	0	Y6
1	1	1	Y7

## Using MSI Logic To Build An Output Port

- A 74HC138 decoder can be used to select a range of addresses
- The outputs of the 74HC138 are used to select up to 8 different devices
- The enable inputs are used to determine when one of the 8 different devices should be selected
- Because the data part of the memory cycle occurs when E is high, the active high enable input is usually connected to the HCS12's E clock
- The active low enable inputs are usually connected to highest-order address lines (A15 and A14), or to combinational logic which is driven by highest-order address lines
- The address inputs of the 74HC138 are usually connected to the next highest-order address bits. Sometimes the low-order address input is connected to the R/W line of the HCS12 to allow separate selection of input and output devices
- For example, on the figure on the next page, A15 and  $\overline{A14}$  are connected to the active low enable inputs. This means that one of the outputs will be selected only when A15 and A14 are low, or for the address range 0x4000 to 0x7fff
- A13, A12 and A11 are connected to the three address inputs of the 74HC138. For example, address Y5 will be low when A13 A2 A11 are 1 0 1. Thus Y5 will be select for addresses from 0010100000000000<sub>2</sub> to 0010111111111111<sub>2</sub>, or from 0x6800 to 0x6fff
- The Y5 output may be connected to a device which needs only one address
  - In this case, the device will be accessed with any address from 0x6800 to 0x6fff
  - This is called partial address decoding — to save expense, we do not decode all address lines, but only enough to put in the number of devices we need
  - We also need to demultiplex only those address lines we decode, which also saves some expense

**HCS12 Memory Map  
(Expanded Mode)**

REGISTERS	0x0000 0x03FF
EEPROM	0x0400 0x0FFF
RAM	0x1000 0x3FFF
OPEN	0x4000 0x7FFF
BANKED FLASH EEPROM	0x8000 0xEFFF
FLASH EEPROM	0xC000 0xFFFF

Can map external device into any unused space

When using Altera for address decoding, can select any desired address.

Can map using less expensive chip like 74HC138

**74HC138**

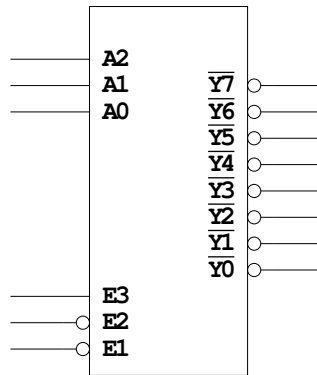

Want to select external device when E is high - Connect E to E3

Will use A15 and A14 as the other enables. This will divide memory into 1/4 of total

A15	A14	Chip enabled?
0	0	0x0000 - 0x3fff
0	1	0x4000 - 0x7fff
1	0	0x8000 - 0xbfff
1	1	0xc000 - 0xffff

### HCL2 Memory Map (Expanded Mode)

REGISTERS	0x0000 0x03FF
EEPROM	0x0400 0x0FFF
RAM	0x1000 0x3FFF
OPEN	0x4000 0x7FFF
BANKED FLASH EEPROM	0x8000 0xBFFF
FLASH EEPROM	0xC000 0xFFFF

Can map external device into any unused space

When using Altera for address decoding, can select any desired address.

Can map using less expensive chip like 74HC13

#### 74HC138

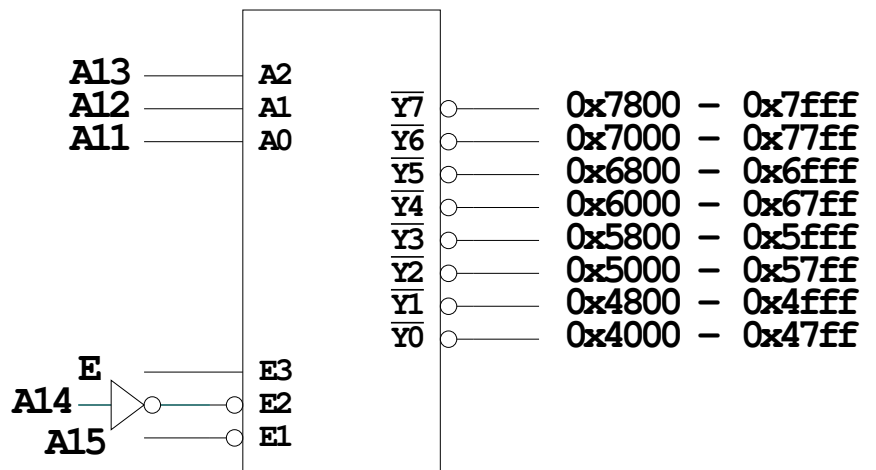

Nothing is mapped into memory spaces occupied by outputs Y2 through Y7

## A Simple Output Port

- We will use some MSI chips to implement a simple output port
- We will use a 74AHC374 chip as our output port — this is a chip which has 8 flip-flops
- We need to demultiplex several of the address lines. We will use another 74AHC374 chip to do this
- We will use a 74AHC138 decoder chip to select the output port
- For this example we will select the output port based on output Y7 from the 74AHC138. For the connections shown of the next page, A15 and A14 must be low, and A13, A12 and A11 must be high to select output Y7. Thus, the output port will be selected for addresses in the range 0x7800 to 0x7fff
- The address port needs to be connected to 8 bits of the address/data bus. We must connect it to either the high (even) byte (AD15-8) or the low (odd) byte (AD7-0). For this example we will connect it to the high byte
- We need to select the output port only when we write to an even address in the range 0x7800 to 0x7fff. In addition to address Y7 being active (low), the R/W line must be low (to indicate a write) and A0 must be low (to indicate an even address). We will use a 3-input OR gate to do this.
- Now, a write to any even address between 0x7800 and 0x7fff will write data to the output port

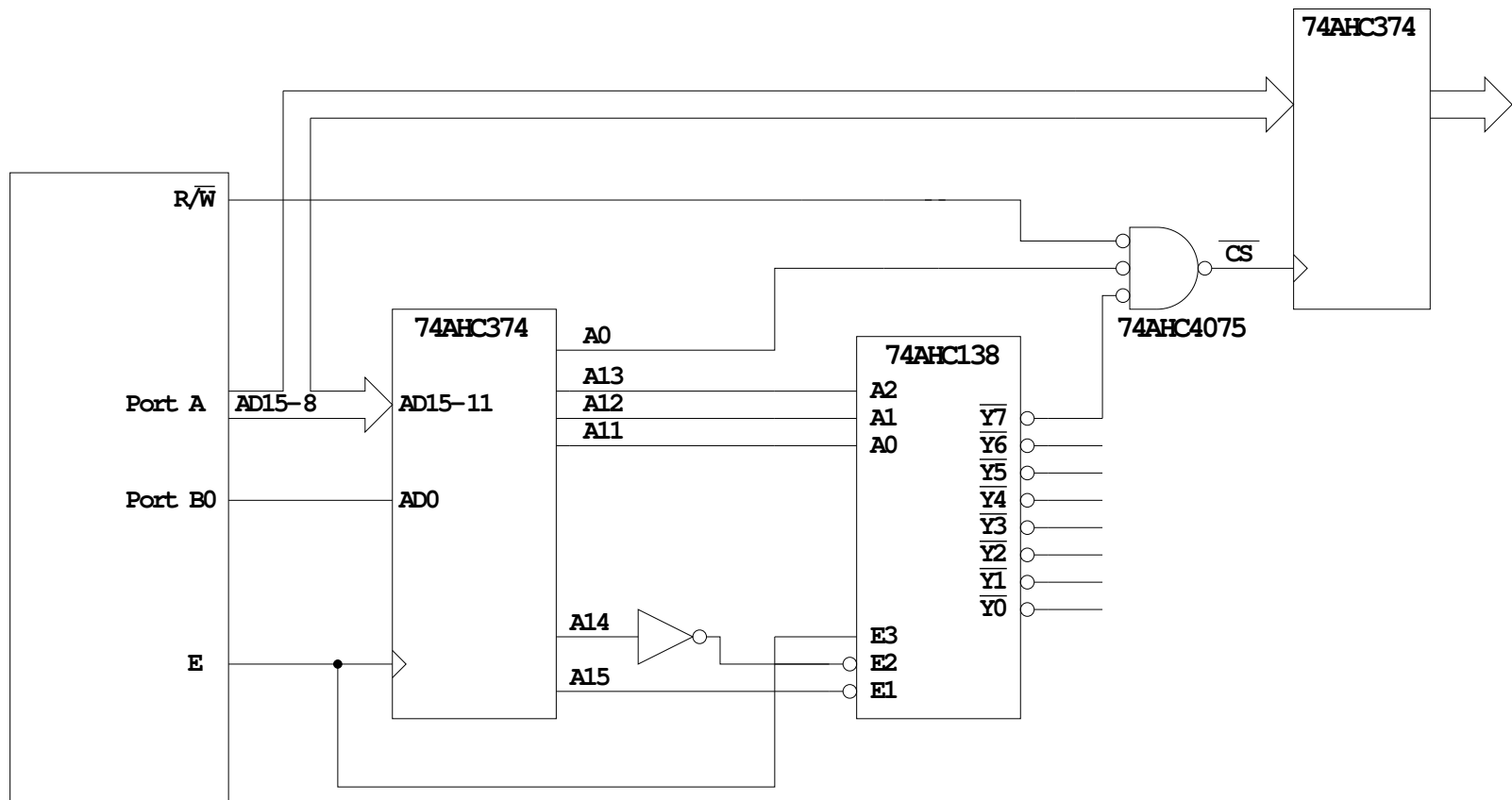

Simple output port for the HC12.

When address is between 0x7800 and 0x7fff and E is high, Y7 will go low

On a write to an even address in this range, CS will go low

Data on AD15-8 will be latched into port when CS goes high (when E goes low)

## A Simple Input Port

- We will design a simple input port in a similar manner
- We will narrow the range of addresses used by using more high-order address lines to enable the 74AHC138. In the example shown, the address range of a single output is 512 bytes. For the output port example above, the range was 4 kB
- For an input port we need a tri-state buffer to drive the input data transparent latch (with tri-state outputs) for our buffer
- In this case we connect the tri-state buffer to the low (odd) data byte
- To access the chip for odd address, we need to select the chip only when LSTRB is low

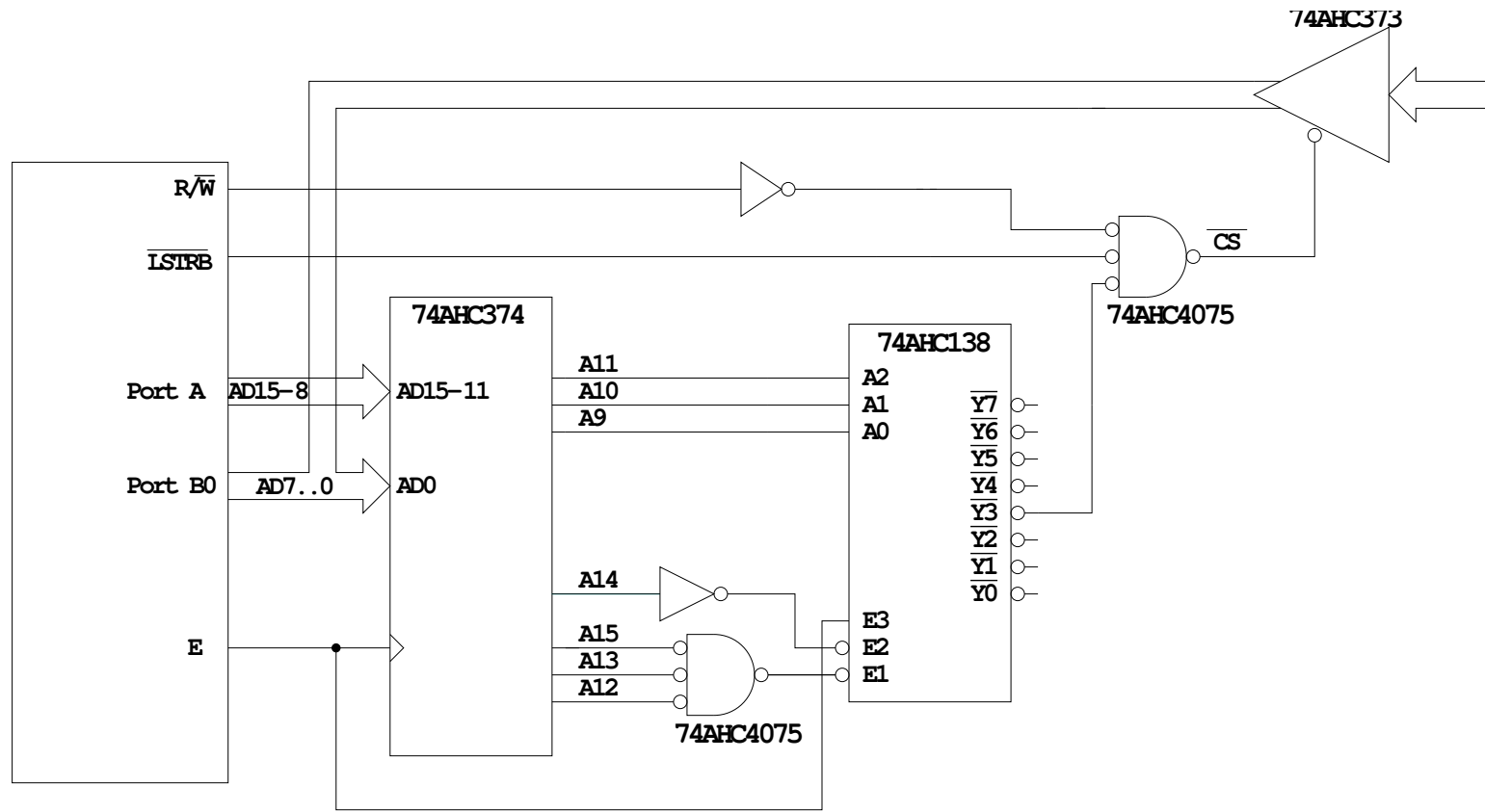

Simple input port for the HC12.

When address is between 0x4600 and 0x47ff and E is high, Y3 will go low

On a read from an odd address in this range, CS will go low

Data from the tri-state buffer will be driven onto AD7-0

The HC12 will latch the data into internal registers when E goes from high to low



### A Simple Input-Output Port

- The next example shows another way to connect the 74138 chip to select input and output devices
- We connect A0 to one of the active low enable inputs. The 74138 will select a device only when A0 is low — only for even addresses
- We connect R/W to the low-order address input of the 74138
  - To select Y0, Y2, Y4 or Y6, R/W must be low. Thus, the devices selected by Y0, Y2, Y4 and Y6 are output devices (devices the HCS12 writes to).
  - To select Y1, Y3, Y5 or Y7, R/W must be high. Thus, the devices selected by Y1, Y3, Y5 and Y7 are input devices (devices the HCS12 reads from).

## Simple Input and Output Ports

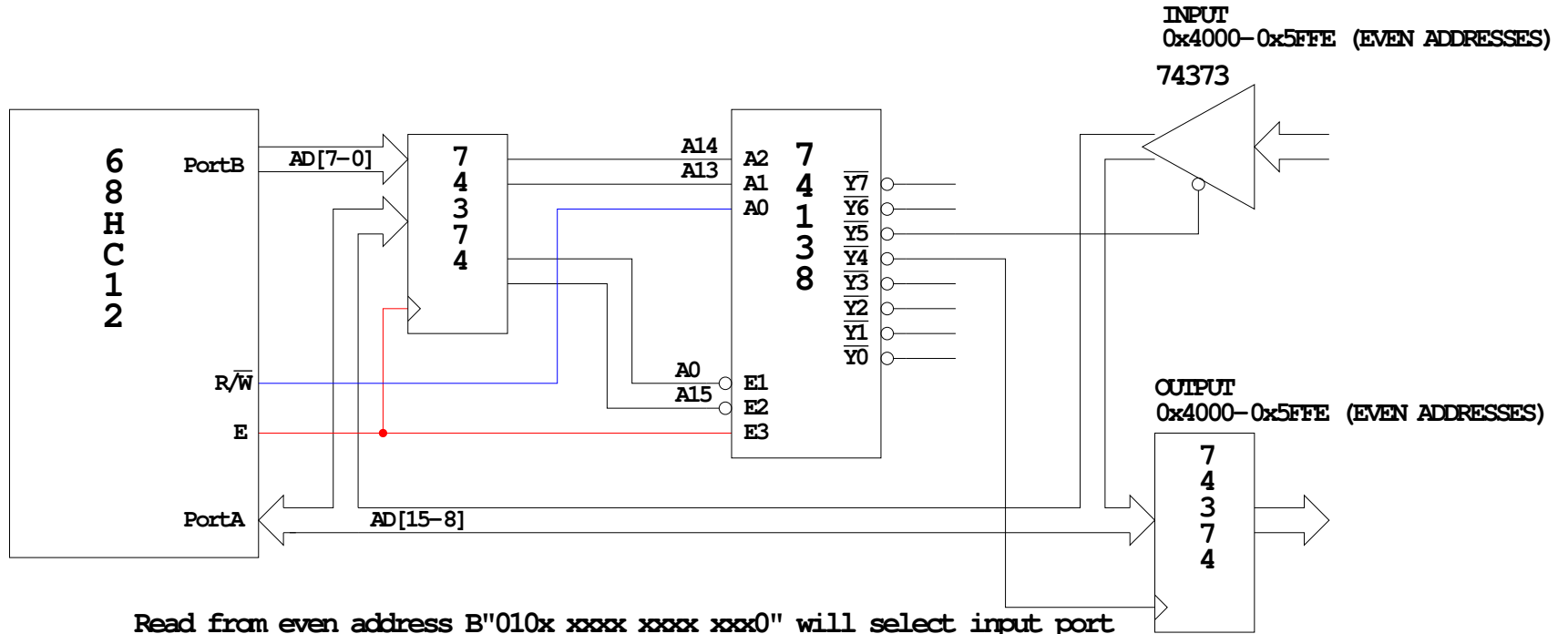

Read from even address B"010x xxxx xxx0" will select input port

Write to even address B"010x xxxx xxx0" will latch data in output port