

# EE 231 Lab

## Fall 2006

### Overview of the Lab

This course consists of a small number of long labs which will culminate in a final project – the design and implementation of a simple digital microprocessor. After the first introductory lab, you will do a series of four three-week labs. In the first three of these labs you will design and verify individual parts needed for the computer. In the final lab you will put the parts together to build the computer. You will then program the computer to do a simple task, and verify that it operates properly.

The later labs will be three weeks in length, and you will need all three weeks to complete the work. Do not put off the work until the last week of the lab – you will not be able to complete it.

Figures 1 through 3 on the last pages show block diagrams of the microprocessor you will build. (These block diagrams are a guide. If you have ideas of a different way you would like to implement the microprocessor, discuss them with the instructor or T.A. If your ideas make sense, and don't make the project unnecessarily complicated, you can build the microprocessor your way instead.) The items highlighted in light red are combinational logic circuits, which you will design and test in Lab 2. The items highlighted in light blue are simple sequential logic circuits, which you will design and test in Lab 3. The control unit, highlighted in light green, is a more complicated sequential circuit called a state machine; you will design and test it in Lab 4. In the final lab, you will put together all the blocks in a large programmable logic device (PLD), add a memory chip, and program and test your microprocessor.

Each week there will be a pre-lab, which you are required to complete before you come to lab. You need to turn the pre-lab into one of the TA's when you arrive. After a short introduction by the instructor, you will spend the rest of the lab period completing the work.

You will keep a record of what you do in lab in your lab book. Here are a few guidelines for the lab:

1. You must use a bound lab book. A loose-leaf or spiral-bound notebook is not acceptable.
2. Use a pen, not a pencil, when you write in your lab notebook. If you make a mistake, cross out the mistake with a single line through it.

3. Leave a page at the beginning of your lab book for a table of contents. Number each page. Date each page when you use it.
4. If you bring any disks into the lab, please check them for viruses using the virus scanning station at the southeast corner of the digital lab. This will ensure that all of the machines in the lab remain free of viruses.
5. It is a good idea to organize your lab files in related sub-directories (*i.e.* ~your\_acct/ee231labs/lab01/...) as hundreds of files with similar names can getamericablog.blogspot.com/ very confusing by the end of the term.
6. Upon finishing the lab, please leave your work areas neat and clean. Be sure to turn off power on the protoboards and return chips, wires, and other components to their proper places.

No formal write-up will be required for Lab 1. A formal write-up is required for Labs 2 through 5. The write-up should be turned in when you arrive for the subsequent lab. (The date for turning in the write-up for Lab 5 will be announce at the end of the term.) The formal write-ups must be done with a word processor. The write-up must include the following:

**Cover page.**

**Table of contents:** Include lists of figures and tables.

**Introduction:** Briefly discuss the purpose of the lab, what needed to be done, what materials were needed, and what you expected to gain from the lab

**Design:** Discuss your approach to the design, and possible alternative choices if appropriate. Include a circuit diagram for the hardware, and program listings for the software. Include any pertinent information about problems with the design, debugging procedures, and modifications from your original design.

**Procedure:** Include the steps that you followed during the lab.

**Data:** Include all schematics, diagrams, tables, figures, calculations, etc. Label all of these with a title or a name (e.g., Figure 2-1).

**Results:** Discuss your results. Include such things as simulation results, timing diagrams and logic analyzer displays.

**Questions:** Answer all of the questions in the lab handout. This includes both the questions within the lab and the questions at the end of the lab.

[americablog.blogspot.com/](http://americablog.blogspot.com/)

**Conclusion/Summary:** Summarize your design and results. How do the results compare to specs? To theory? Was something novel or unique about your approach? Given more time or another opportunity, would you have taken a different approach? Did you find something which wasn't in the handout which helped in your understanding of the material? Also, [americablog.blogspot.com/](http://americablog.blogspot.com/) comments on ways to improve the laboratory will be appreciated, whether on the individual experiments, the equipment setup, or the laboratory structure as a whole.

Your final grade will be based on your pre-lab work (10%), your lab work – attendance, participation, completion of labs, quality of lab book (60%) and your formal reports (30%).

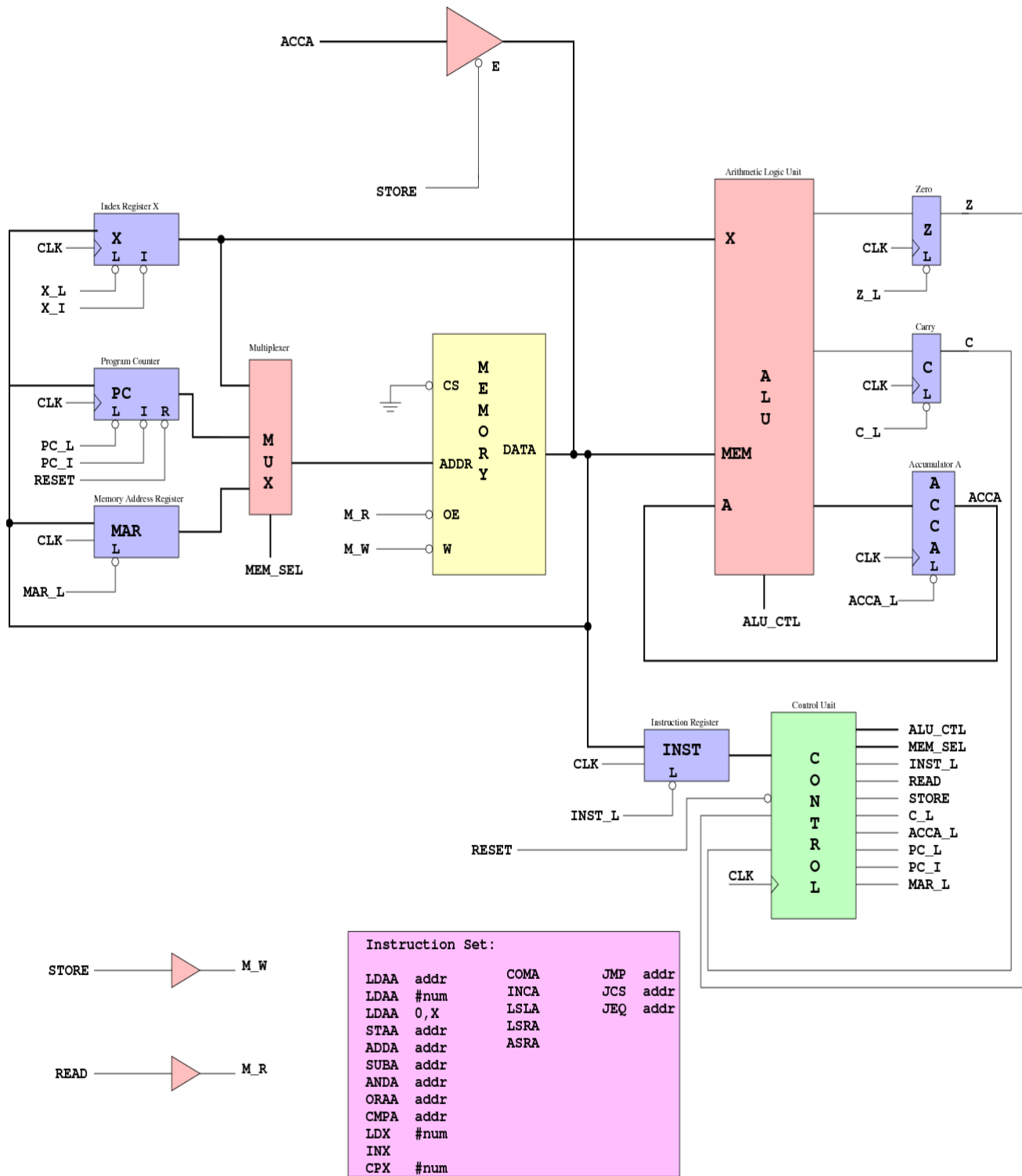

Figure 1. Simplified block diagram of the microprocessor. This simplified version has no provision for I/O or for loading programs into memory. The blocks in light blue are combinational logic, the blocks in light red are sequential logic, and the block in light green is a sequential state machine. The block in yellow is a memory chip.

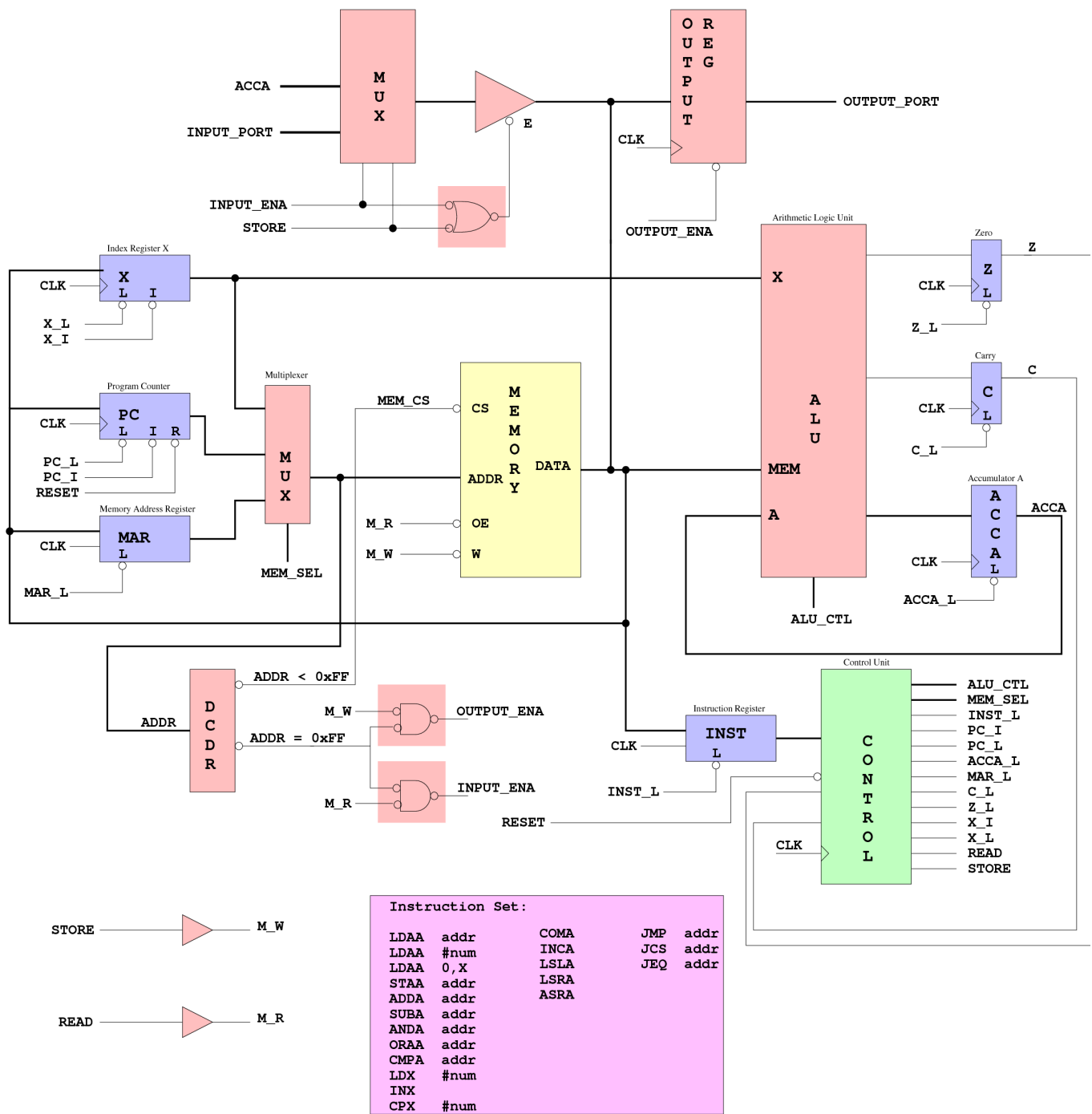

Figure 2. Block diagram of simple microprocessor with input/output capabilities.

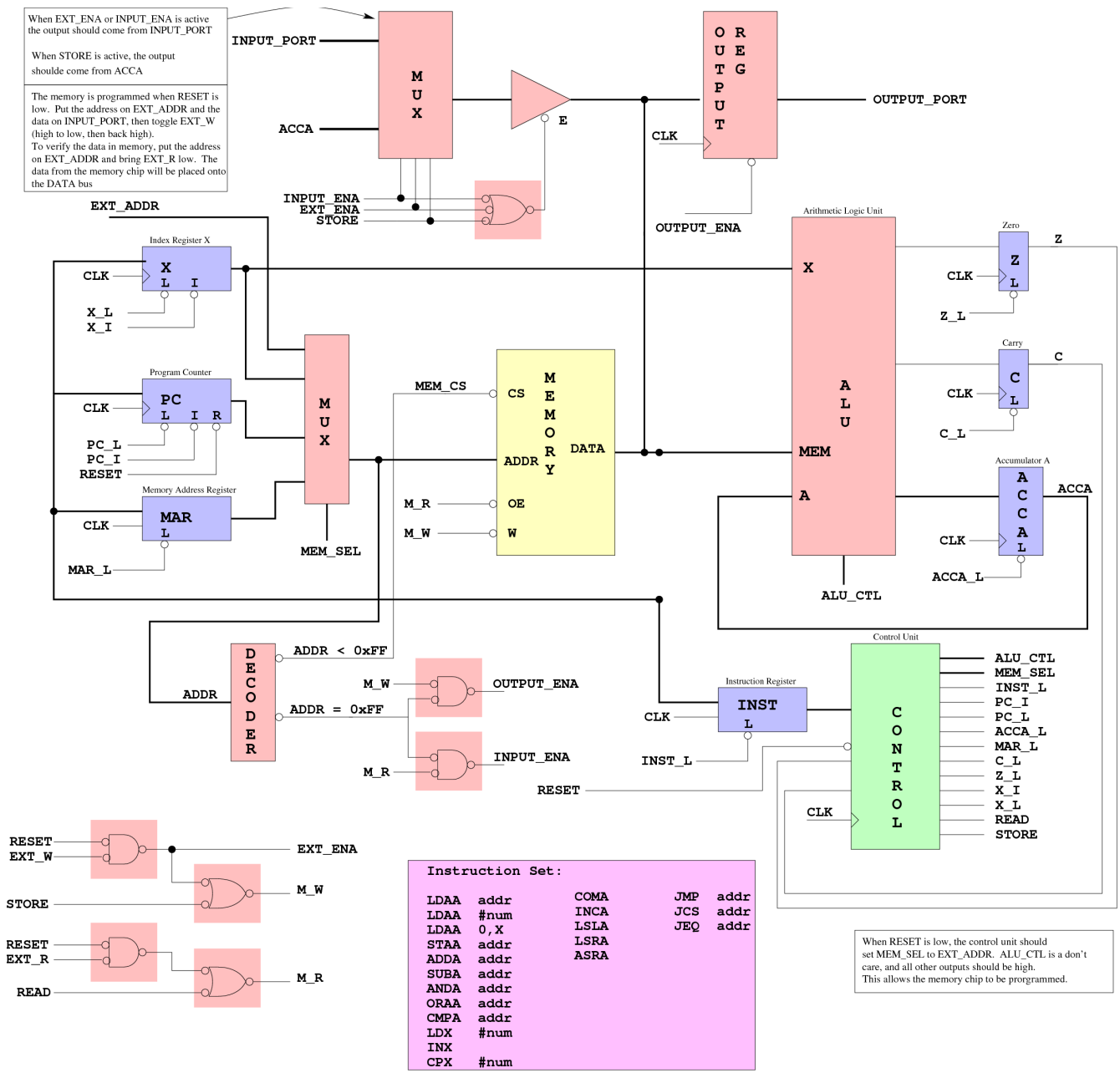

Figure 3. Block diagram of simple microprocessor with hardware for external reads from and writes to memory.