

EE321 – Lab 6

Diodes, Part 3 — Diode and Zener Diode Circuits

The purpose of this lab is build and test some interesting non-linear circuits.

Zener Circuits

1. Construct a simple voltage regulator (similar to figure 3.23a in Sedra and Smith) to produce 8.2 V from a 15 Volt source, using your 1N5237 zener. Make the zener current equal to 20 mA, approximately. Sketch circuit and measure the output voltage with your digital multimeter.
2. Apply a 1 K Ω load to the regulator and measure the voltage change. What incremental zener resistance $r_z = \Delta v_z / \Delta i_z$ does this imply? Compare with spec.
3. Apply a 100 Ω load to the regulator. What happens, and why? In theory, what is the smallest load resistance that could be applied and still have the regulator output at approximately 8.2 volts? Test.
4. How much does the output voltage change when the supply voltage is varied from 13 to 17 volts with the 1 K Ω load in place? What percentage regulation $\Delta v_{out} / \Delta v_{in}$ does this correspond to? Calculate this regulation from r_z .
5. The circuit in Figure 1 can be used as a precision voltage source (Horowitz and Hill, 2nd ed., Fig. 6.21). In this circuit, the source of voltage for the zener regulator is the precision output voltage. The precision voltage is obtained by amplifying the zener voltage. Note that the -V connection of the op amp is connected to ground instead of -15 V. (This is to prevent the bootstrap circuit from turning the diode on in the forward direction.)

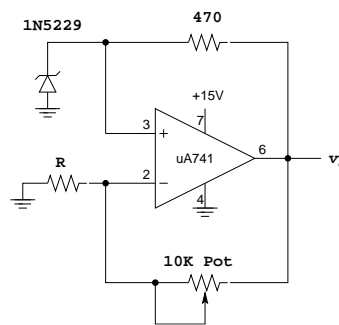

Figure 1.

- Adjust the pot to produce exactly 10.00 volts output, as measured with your digital multimeter. How close did you get?
- Test that the output voltage is constant independent of the +15 V supply voltage (within limits).
 - What are the limits? Explain why this makes sense.
 - How much did it change when the supply is within the limits?
- Measure the zener voltage and the value of the resistance of the pot. Is the pot resistance what it should be?

Limiting, Clipping, Clamping, and Doubling Circuits

6. Construct the double diode limiter (shown in Figure 2) using IN4001 diodes. Describe the output for a 1 V amplitude sine input. Use the X-Y mode to plot the transfer function. Observe both input and output on the same scale and note why the circuit is called a clipper.

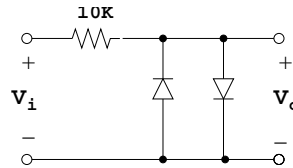

Figure 2.

7. Use two 4.3 V zeners in series as shown in Figure 3. With a larger input what does the circuit do? Plot the transfer function. Explain the transfer function (knowing the the zener voltage at 0.1 mA helps).

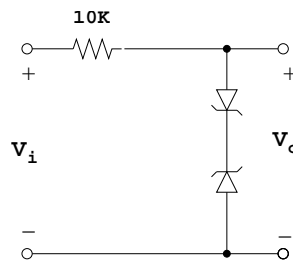

Figure 3.

8. Construct the clamped capacitor circuit (Figure 4) making sure the polarity of both the capacitor and the diode are correct. Test it with 4 V peak-to-peak sine input. Describe the effect of the circuit (account for the voltage drop across the diode in your explanation). Add an offset to the sine input, what is the effect? Why?

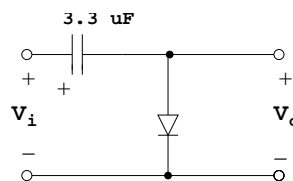

Figure 4.

9. Keep the clamped capacitor circuit and build the rectifier (Figure 5). Measure and explain the output of the rectifier, when the input is a 4 V p-p sine from the signal generator. Next use the output of the clamped capacitor as an input to the rectifier of Figure 5. Sketch the total circuit. Measure and explain the output. What would you call this circuit?

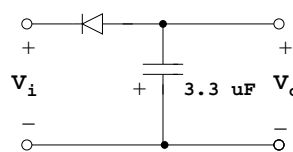

Figure 5.

Pre-Lab

1. Consider the zener regulator shown in Figure 3.23a in Sedra and Smith.
 - Find R so that the zener current will be equal to 20 mA with no load (use the conditions of Part 1 of the lab).
 - Add a 1 k Ω load to the circuit. Calculate the current in the load and the zener. If the zener resistance $r_z = 10 \Omega$, how much will V_o change?
 - Find r_z from the [datasheet](#).
 - What is the load regulation using r_z from the [datasheet](#)?
 - What is the largest load current this regulator can deliver and still have at least 1 mA through the zener? What load resistance does this imply?
 - What is the line regulation using r_z from the [datasheet](#)?

2. Consider the precision voltage source in Figure 1.
 - Find R to give the proper gain (4.2 V in and 10.0 V out) with the pot set at its mid point.
 - The circuit appears to have positive feedback. Why doesn't it? Hint - if the output changes will the voltage at pin 3 change?

3. From the data sheet find the voltage of a 4.3 V zener with only 0.1 mA through it. (Look at Fig 11 of the [datasheet](#). The 4.3 V zener has 4.3 V at 20 mA).