

## EE321

Diodes, Part 1 — The  $I$ - $V$  Characteristics of Diodes

The purpose of this lab is to investigate the  $i$ - $v$  (current-voltage) characteristics of rectifier and zener diodes.

## Rectifier Diodes

1. Use the circuit in Figure 1 to display the  $i$ - $v$  characteristic of the 1N4001 rectifier diode on your scope using its X-Y capability. This is very similar to the method we used to measure the transfer function in Lab 1. Note that in Figure 1 the ground of the oscilloscope is not the same as the ground of the circuit. Many instruments receive their ground reference through the power cord, including our scope, power supply, and signal generator, to prevent potentially dangerous shocks. By using the isolation transformer between the function generator and the wall power you may break this reference and set a new reference by the output connections.

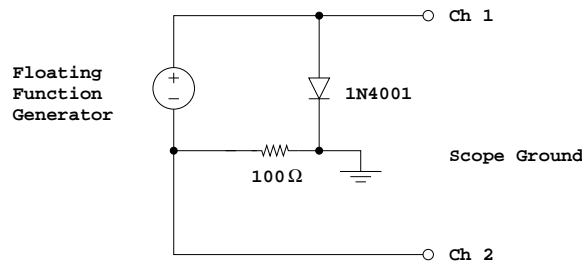

Figure 1.

Check the 1N4001 [datasheet](#). What is the maximum forward current and maximum reverse voltage the diode can handle? Can your function generator exceed these values?

Change your scope inputs/settings to obtain a ‘normal-looking’  $i$ - $v$  characteristic (e.g. Sedra and Smith p. 132). Vary the amplitude of the signal generator and observe the X-Y trace. At what voltage (within 0.1 V) does the diode appear to ‘turn on’ (current starts to flow)?

2. Sketch the  $i$ - $v$  curve. Be sure your amplitude is large enough so the current reaches at least 20 mA. Label axes and add voltage and current scales. Determine the forward voltage when the current is 1 mA and 10 mA (use the time mode and cursors). Does the forward characteristic remain exponential up to the maximum forward current? (Can you tell?)
3. Remove the diode from the circuit and use the diode setting of your multi-meter to check the diode. In this setting the multi-meter puts 1 mA into your diode and measures the voltage. How does this compare to your result from Part 2?

## Zener Diodes

4. Using the setup of Figure 1 display and sketch the  $i$ - $v$  characteristics for the 1N5229 and 1N5237 zener diodes. For each diode, measure the zener voltage at a reverse current of 20 mA and compare with the specification values from the [datasheet](#). Which diode has the steeper slope in the breakdown region? Which would make a better voltage regulator?

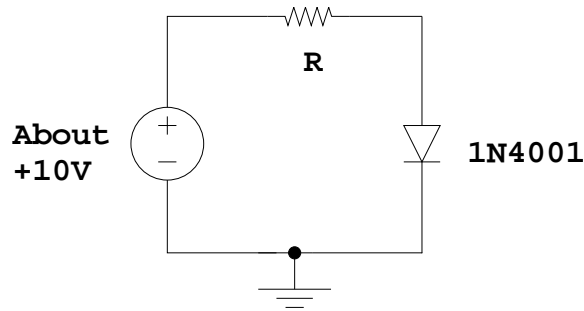

Figure 2.

5. Each of the zener diodes has a 500 mW power rating. What maximum steady zener current does this imply?

### Diode Forward Characteristics

6. Compute the parameters  $n$  and  $I_S$  which govern the forward diode characteristic by measuring  $I_D$  and  $V_D$  at two points in the forward bias region of your 1N4001 diode. Use the circuit shown in Figure 2 (do not use the function generator or scope this time). Make measurements using a 1 k $\Omega$  (to give  $I_D = 10$  mA) and then a 10 k $\Omega$  (to give  $I_D = 1$  mA) current limiting resistor. Adjust the 15 V power until the voltage across the resistor is 10 V, and measure the diode voltage. (Do this accurately using a digital multi-meter to measure the voltage across the current-limiting resistor.) Sketch circuit and show calculations for  $n$  and  $I_S$  (Ref: Sedra and Smith p. 132-134).

Compare the 1 mA voltages of parts 2, 3 and 6. If the difference is more than 20% repeat and carefully check each measurements.

7. Measure the incremental resistance  $r_d$  of the above diode at DC bias current  $I_D = 1$  mA (see figure 3.25 in Sedra and Smith). Use the circuit in Figure 3 and your **oscilloscope**. (The floating signal generator provides a "small signal"  $v_d, i_d$  around the bias point set by the dc power supply. Observe the small signals using AC coupling on the scope.) The incremental resistance is given by  $r_d = v_d/i_d$ . Compare your measurements with the theoretical value for  $r_d$  (Eq 3.53 in Sedra and Smith).

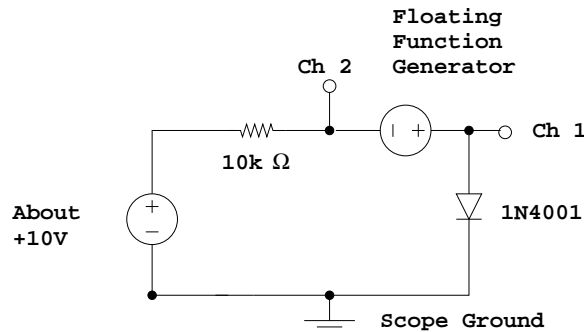

Figure 3.

**Pre-Lab**

1. Use the diode equation (eq 3.1 in Sedra and Smith) to find the expected  $i_D$  for  $v_D = 0.1, 0.2, 0.3, 0.4, 0.5, 0.6, 0.7$  and  $0.8$  V (let  $I_S = 30 \times 10^{-8}$  A and  $n = 2$ ).
2. If you had measured the diode current  $i_D = 1$  mA at  $v_D = 0.6$  V and  $i_D = 10$  mA at  $v_D = 0.7$  V, find  $I_S$  and  $n$  for that diode.