

EE321 Lab

Diodes, Part 2 — Rectifier Circuits

The purpose of this laboratory is to investigate the use of diodes in rectifier circuits and to build precision rectifiers.

Half Wave Rectifiers

1. Construct the simple half-wave rectifier shown in Figure 1 (use a 1N4001 diode). Test its operation at 100 Hz for a range of input amplitudes, from 20 V p-p down to 1 V p-p, by superimposing the input and output waveforms on your scope. Describe your results, and sketch a sample waveform.

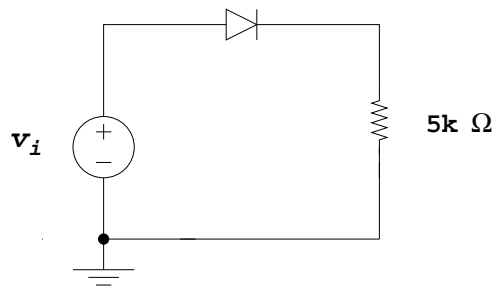

Figure 1

2. How well does the rectifier work at higher frequencies (keep the input at 1 V p-p)? The undershoot that you observe at 100 kHz is caused by diode capacitance. Temporarily replace the rectifier diode (large capacitance) with a 1N4148 switching diode (low C). This should reduce the switching transient.
3. Replace the diode in your circuit with the ‘superdiode’ shown in Figure 2 (use the 1N4148 switching diode). Repeat the above measurements, using a low input frequency (about 100 Hz).

Does this give better rectification, and why? Increase the signal frequency to about 2 kHz. What causes the delayed turn-on of the rectifier? (Hint: Look at the output of the op amp on the other trace.)

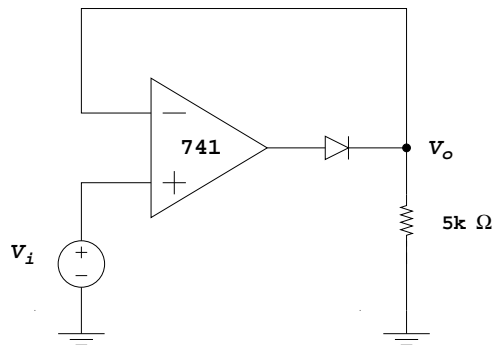

Figure 2

- Substitute a 411 op amp for the 741. Compare the behavior of the two rectifiers at 2 kHz frequency. Why is the performance improved with the 411? (Hint: Look at the output of the op amp on the other trace.)

Full Wave Rectifiers

- Construct the “bridge” rectifier (Figure 3) using a transformer to float the signal generator (10-20 V p-p, 100 Hz) and the 1N4001 diodes. Be sure to connect diodes as shown. Use a load resistor of 5 k Ω .

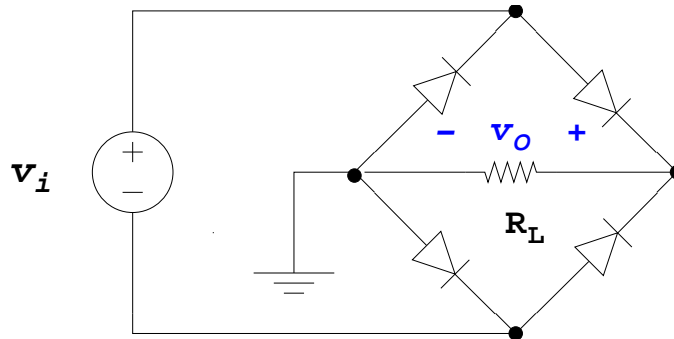

Figure 3

- Verify that the output is full-wave rectified. Sketch the output waveform for a 3 V p-p input. What is the flat part of the output waveform caused by? (Hint: How much voltage V_i is required to turn the diodes on?) Because the grounds of the signal generator and the output are different, both the input and output can NOT be viewed at once. The voltage between the positive side of the signal generator and rectifier ground is difficult to interpret.
- Place a 10 μF capacitor across the load resistance, being careful to observe the polarity of the electrolytic capacitor. The input signal should be 10 V p-p. Sketch the output waveform and compare to the waveform without the filter capacitor. Measure the average DC voltage and peak voltage. Explain the waveform. Why is this called ‘filtering’ the output?
- Measure the p-p “ripple” on the output, both amplitude and frequency. How does the frequency compare to the input frequency? Compare the p-p ripple amplitude with its theoretical value. (To measure the ripple, AC couple your oscilloscope.)

Pre-Lab

1. Consider the ‘superdiode’ shown in Figure 2. Sketch the waveforms you would expect at the output of the op-amp and the top of the resistor. Consider the following:
 - If V_o is positive which way is current flowing in the load resistor? Where is the current coming from? Which way is current flowing in the diode? What voltage would you expect at the output of the op-amp?
 - Do the same for V_o negative.

2. Consider the “bridge” rectifier of Figure 3.
 - Sketch the current path thru the diodes during each half-cycle (first when the sine input is positive and then when it is negative). Indicate the voltage drop across each diode and the resistor.
 - Reverse any one diode and draw the current paths and find voltages as above. What would the result be if you did this in the lab?

3. Consider the ‘ripple’ voltage for a full wave rectifier as you will use in Part 8. There will be a $5\text{ k}\Omega$ load and a $10\ \mu\text{F}$ capacitor. First sketch a figure of the waveform as in Figure 3.30 in Sedra and Smith with correct time and voltage scales (use $V_i = 10\text{ V}$ p-p at 100 Hz).
Use three methods to find the ripple amplitude. Calculate a number for each method.
 - (a) Use $\Delta v_o/\Delta t \approx i/C$ for $RC \gg T$ to find the voltage drop. Show that this gives a peak-to-peak ripple voltage of iT/C where T is the period of the rectified signal.
 - (b) Use $V = V_{peak}e^{-t/\tau}$ for the voltage drop. Show that this gives a peak-to-peak ripple voltage of $V_{peak}(1 - e^{-T/\tau})$.
 - (c) Use a formula developed in the rectifier section of the book when $RC \gg T$.

Reduce the load resistance to $100\ \Omega$, and find the ripple voltage by the three methods. Which make sense, and which don't?