

EE321 Lab

Strain Gauges — Using Instrumentation Amplifiers

In this lab we will experiment with differential amplifiers and use a so-called ‘instrumentation amplifier’ to measure the output of a strain gauge. The instrumentation amplifier is a high-gain high-input-impedance high-CMRR differential amplifier.

Differential Amplifiers

1. Construct the following differential amplifier (Figure 1) with R_1 between 4 and 6 k Ω and the difference of v_A and v_B amplified by about 30. Build it in the center of your protoboard to leave plenty of room for later additions.

Connect v_B to ground and v_A to the signal generator, and check that the gain is about 30. With the difference signal set to zero (as shown in the common-mode test circuit, figure 2) test that the circuit attenuates or rejects a common-mode input signal V_{cm} , and measure the ‘gain’ of the amplifier for a common mode signal. Use a common mode input $V_{cm} = 10$ V p-p at 100 Hz. Why is the output not zero?

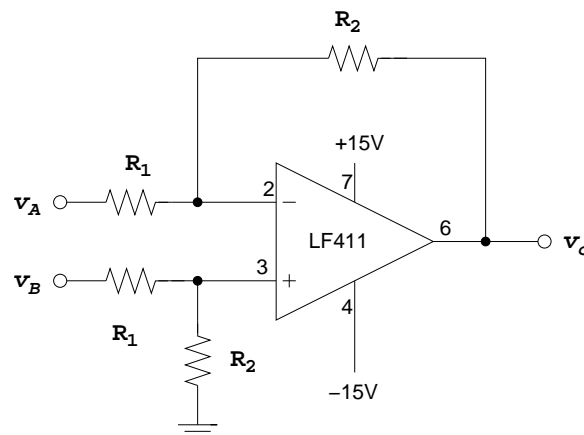

Figure 1.

2. Improve the common mode rejection by replacing part of R_2 in the non-inverting leg with a potentiometer (with the pot set to the middle of its range, the total resistance replacing R_2 should be equal to R_2). Adjust to maximize the common mode rejection, determine the new common mode gain and sketch the circuit. Why has the common mode rejection been improved?
3. The ‘Common Mode Rejection Ratio’ (CMRR) is defined as the ratio of the signal gain to the common mode gain. Compute the CMRR of the above circuit as both (V/V)/(V/V) and dB.

Instrumentation Amplifier

4. Convert your differential amplifier to the classical ‘instrumentation amplifier’ shown in Figure 3 by adding a non-inverting amplifier to each input. Use 411 op amps for each of the

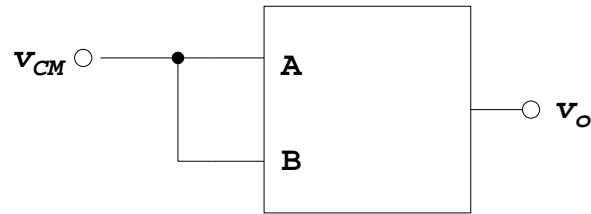

Figure 2.

non-inverting stages. Lay the circuit out neatly. Select the resistance values to give the amplifier an overall gain of about 600 to a differential input signal. Sketch circuit and test its operation by checking that all levels are zero when the inputs are grounded (adjust R_5 so the output is less than a volt). Check to see that a common mode input is rejected (Figure 2). Check to see that the gain is near 600. (If the circuit does not pass these tests, revert to trouble-shooting mode.)

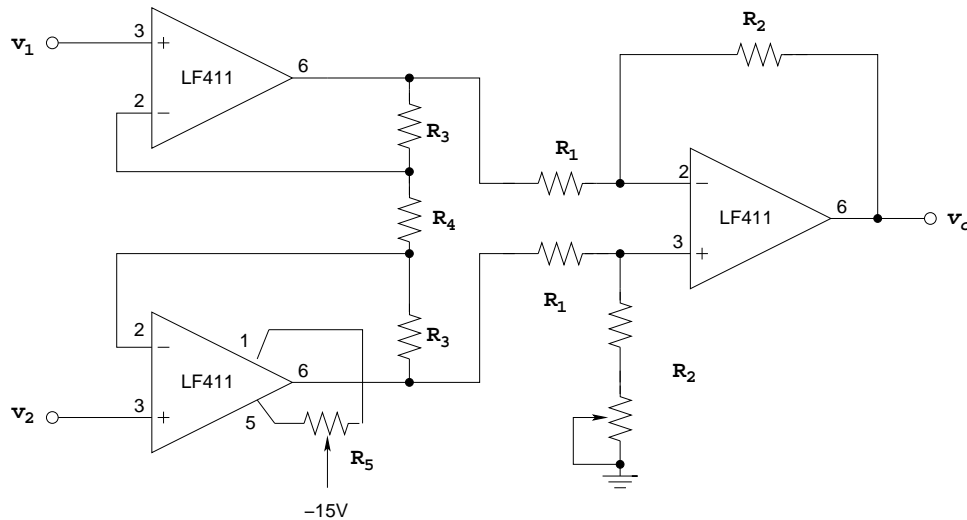

Figure 3.

5. The resistance of a strain gauge changes by a few tenths of an ohm as it is stretched or compressed. The Wheatstone bridge is used to convert the small change in resistance to a small voltage.

- Connect the output voltage v_O of the Wheatstone bridge to the input(s) of your instrumentation amplifier.
- Balance the bridge so that your output is close to 0 V.
- Measure the change in voltage of the strain gauge bridge as the bar moves up and down.
- How small of a deflection of the bar can you detect?
- How small of a change in resistance does this correspond to?

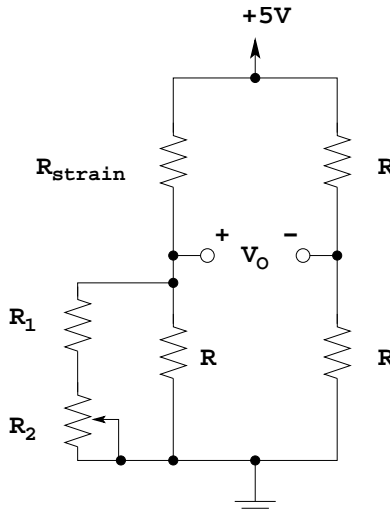

Figure 4.

Pre-Lab

1. Consider the difference amplifier shown in Figure 1 of the lab and Section 2.4.1 of Sedra and Smith. Design the amplifier with a differential gain of about 30 with R_1 between 4 and 6 k Ω .
2. Consider the instrumentation amplifier shown in Figure 3 of the lab and Section 2.4.2 of Sedra and Smith. Design the amplifier with a total differential gain of about 600, that is $V_O = 600(V_1 - V_2)$ (note the differential gain of 30 is part of this).
3. Why would one use an instrumentation amplifier with a gain of 600 instead of a difference amplifier with the same gain?
4. Consider Wheatstone bridge in Figure 4 (ignore R_1 and R_2 initially). This simple four resistor circuit has been used for many years to convert a change in small resistance to a proportional change in output voltage.
 - Assume that the resistance of the strain gauge is equal to R . Show that V_O is 0.0 V. Hint: each side of the bridge is a simple voltage divider.
 - Find V_O if the resistance of the strain gauge increased by 0.1%.
 - Find V_O if the resistance of the strain gauge decreased by 0.1%.
 - The resistance of the strain gauge is close to 120 Ω . The other resistors, R are about 121 Ω . R_1 and R_2 are used to balance the bridge (set V_O to 0.00 V). If R_1 and R_2 are both 10 K Ω , what is the minimum and maximum of the parallel resistance of that section of the bridge?