

Fig. P3.26

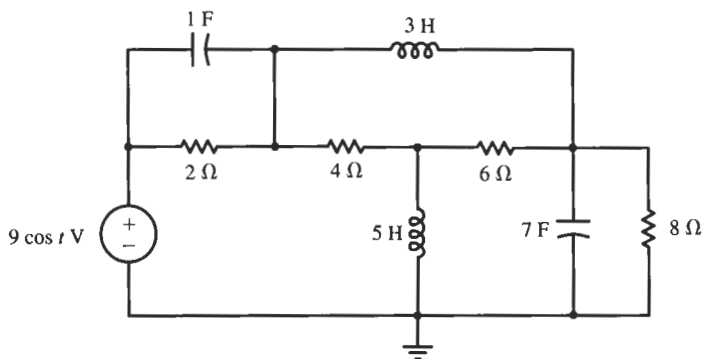

Fig. P3.27

3.29 For the circuit shown in Fig. P3.28, replace the capacitor with a 5-H inductor. For the resulting circuit, the switch opens at time $t = 0$ s. Write a differential equation in $i(t)$ for $t \geq 0$ s. Find $i(t)$ and $v(t)$ for all time and sketch these functions.

3.30 For the circuit shown in Fig. P3.30, suppose that $i_s(t) = 10$ A for $t < 0$ s and $i_s(t) = 0$ A for $t \geq 0$ s. Write a differential equation in $i(t)$ for $t \geq 0$ s. Find $i(t)$ and $v(t)$ for all time and sketch these functions.

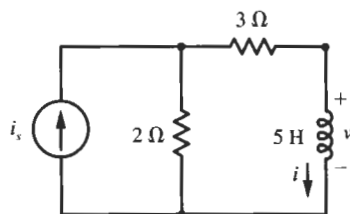

Fig. P3.30

3.31 For the circuit shown in Fig. P3.30, replace the inductor with a 0.1-F capacitor. Suppose that $i_s(t) = 10$ A for $t < 0$ s and $i_s(t) = 0$ A for $t \geq 0$ s. Write a differential equation in $v(t)$ for $t \geq 0$ s. Find $v(t)$ and $i(t)$ for all time and sketch these functions.

3.32 For the circuit shown in Fig. P3.32, suppose that $v_s(t) = 18$ V for $t < 0$ s and $v_s(t) = 0$ V for $t \geq 0$ s. Write a differential equation in $i(t)$ for $t \geq 0$ s. Find $i(t)$ and $v(t)$ for all time and sketch these functions.

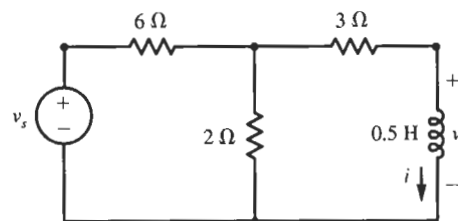
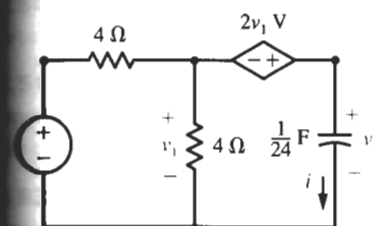

Fig. P3.32

33 For the circuit shown in Fig. P3.32, replace the inductor with a $\frac{1}{9}$ -F capacitor. Suppose that $v_s(t) = 18$ V for $t < 0$ s and $v_s(t) = 0$ V for $t \geq 0$ s. Write a differential equation in $v(t)$ for $t \geq 0$ s. Find $v(t)$ and $i(t)$ for all time and sketch these functions.

34 For the circuit shown in Fig. P3.34, suppose $v_s(t) = 12$ V for $t < 0$ s and $v_s(t) = 0$ V for $t \geq 0$ s. Write a differential equation in $v(t)$ for $t \geq 0$ s. Find $v(t)$ and $i(t)$ for all time and sketch these functions.



P3.34

35 For the circuit shown in Fig. P3.34, replace the capacitor with a 3-H inductor. Suppose that

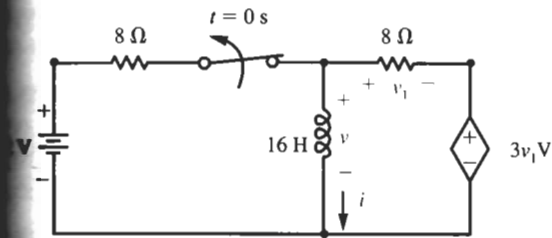

P3.36

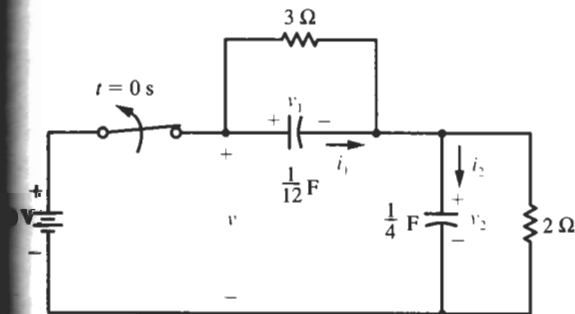

P3.38

$v_s(t) = 12$ V for $t < 0$ s and $v_s(t) = 0$ V for $t \geq 0$ s. Write a differential equation in $i(t)$ for $t \geq 0$ s. Find $i(t)$ and $v(t)$ for all time and sketch these functions.

3.36 For the circuit shown in Fig. P3.36, the switch opens at time $t = 0$ s. Write a differential equation in $i(t)$ for $t \geq 0$ s. Find $i(t)$ and $v(t)$ for all time and sketch these functions.

3.37 For the circuit shown in Fig. P3.36, replace the inductor with a $\frac{1}{8}$ -F capacitor. For the resulting circuit, the switch opens at time $t = 0$ s. Write a differential equation in $v(t)$ for $t \geq 0$ s. Find $v(t)$ and $i(t)$ for all time and sketch these functions.

3.38 For the circuit shown in Fig. P3.38, the switch opens at time $t = 0$ s. Find $v_1(t)$, $v_2(t)$, $i_1(t)$, $i_2(t)$, and $v(t)$ for all time.

3.39 For the circuit shown in Fig. P3.38, change the value of the 2- Ω resistor to 1 Ω . The switch in the circuit opens at time $t = 0$ s. Find $v_1(t)$, $v_2(t)$, $i_1(t)$, $i_2(t)$, and $v(t)$ for all time.